

Memorandum



Date: (Public Hearing: 12-6-22)
November 1, 2022

To: Honorable Interim Chairman Oliver G. Gilbert, III
and Members, Board of County Commissioners

From: Daniella Levine Cava
Mayor

A handwritten signature in blue ink that reads "Daniella Levine Cava".

Subject: Ordinance Creating the West Lake Shopping Center Street Lighting Special Taxing District

Agenda Item No. 5(D)

Executive Summary

The purpose of this item is to gain authorization from the Board of County Commissioners (Board) to create a special taxing district in unincorporated Miami-Dade County (County) for the installation of streetlights in the public Rights-of-Way.

Recommendation

It is recommended that the Board approve a petition submitted in accordance with Article 1, Chapter 18, of the Code of Miami-Dade County (Code) for the creation of the West Lake Shopping Center Street Lighting Special Taxing District (Special Taxing District). The creation of this Special Taxing District is a subdivision requirement pursuant to Chapter 28 of the Code.

Scope

This proposed Special Taxing District lies within Commission District 10, which is represented by County Commissioner Anthony Rodríguez, and will provide street lighting services.

Fiscal Impact/Funding Source

Creation of this Special Taxing District will result in no economic impact to the County budget, and there will be no increase or decrease in County staffing. The developer, pursuant to Chapter 18 of the Code, is required to fund the Special Taxing District's first year's lease of the equipment and electricity costs to operate the street lighting system and all incidental costs incurred by the County for the creation and administration of the Special Taxing District.

After the first year, there will be a perpetual annual special assessment for the cost of street lighting to all property owners within the Special Taxing District. Florida Power and Light (FPL) is the owner of the system and will derive revenues from the creation of the Special Taxing District. FPL's contractors and subcontractors may increase their staffing levels to provide the service requirements created by this Special Taxing District.

Social Equity Statement

The proposed Ordinance creates the Special Taxing District, pursuant to Article I, section 1.01(A)(11) of the Miami-Dade County Home Rule Charter and Chapter 18 of the Code. If approved, property owners within the proposed Special Taxing District will pay special assessments appropriately apportioned according to the special benefit they receive from the Special Taxing District's service, regardless of their demographics, and that the total estimated amount of the special assessment to be levied would not be in excess of such special benefit. The creation of this Special Taxing District, which was requested by 100% of the property owners, will provide for lighting continuity between contiguous Street Lighting Special

Taxing Districts on connecting roadways, allow for higher intensity spotlighting at specific locations, and accommodate future County lighting standards.

Pursuant to section 18-20.2 of the Code regarding notice to purchasers of new residential property, it shall be the obligation of a seller of new residential property to provide the purchaser thereof with notice either of the existence of a special taxing district created pursuant to this Chapter of the Code or of a pending petition to create such a special taxing district. The notice shall be provided in the manner set forth in section 18-20.2 of the Code.

Track Record/Monitor

The Special Taxing District will be managed by the Parks, Recreation and Open Spaces Department (PROS) and overseen by the Chief of the Special Assessment Districts Division (Division), Liset Romero-Lopez.

Delegation of Authority

This item authorizes the County Mayor or County Mayor's designee to execute lighting agreements, as required by FPL to provide street lighting, following approval by the County Attorney's Office as to legal sufficiency.

Background

In accordance with the provisions of Chapter 18 of the Code, a petition to create the Special Taxing District, duly signed by 100% of the owners of property within the proposed Special Taxing District, was filed with the Clerk of the Board. A copy of the petition was sent to the County Mayor and the County Attorney to examine and to file a written report with the Clerk certifying that such petition was sufficient in form and substance and signed and properly presented in accordance with the requirements of Chapter 18 of the Code. PROS compiled and filed with the Clerk a memorandum and accompanying written report and recommendations (Report), a copy of which is attached to this memorandum. The Report sets forth the boundaries of the Special Taxing District, an estimate of the cost of the improvements and/or services to be provided, the need for and desirability of the Special Taxing District, the ability of the affected properties to bear the special assessments, certifies that the improvements and/or services to be provided conform to the master plan of Miami-Dade County, and recommends that the Special Taxing District be created to provide a special benefit to all property within the proposed Special Taxing District.

Contingent upon Board approval of the creation of this Special Taxing District, the street lighting services will be accomplished pursuant to an agreement between the County and FPL. The facilities provided will remain the property of FPL. FPL will be responsible for the maintenance, repairs, upgrades, and replacement of the light fixtures, lamps, poles, and all connecting service lines. The Division will administer FPL's agreement, installation, and billing process. This Special Taxing District lies within the boundaries of, and is compliant with the regulations of the Bird Road Corridor Community Urban Center Area District.

Boundaries:

- On the North, theo. SW 38 Way;
- On the East, SW 109 Avenue;
- On the South, SW 40 Street (Bird Road);
- On the West, SW 110 Avenue.

Number of Parcels:	5 (Tentative plat proposes a retail outlet)
Number of Owners:	1
Number of Owners with Homestead Exemption Signing Petition:	None – The petition was submitted by MMG Westlake LLC., the sole property owner and developer.
Type of Improvements:	It is expected that the Special Taxing District will install, operate, and maintain two (2)–7,500 Lumens, 4000K bracket-arm LED streetlights mounted on existing wood poles. At the discretion of the PROS Director, PROS reserves the right to adjust the quantity, style, and luminosity of the street lighting installations, for reasons including, but not limited to, changes in field conditions, to address safety concerns, to provide for lighting continuity between contiguous Street Lighting Special Taxing Districts on connecting roadways, to allow higher intensity spotlighting at specific locations, and to accommodate future County lighting standards.
Public Hearing Notification:	The Clerk will certify the place, date, and hour for a public hearing on the petition and the Report at which all interested persons will be afforded the opportunity to present for this Board’s consideration their objections, if any, to the creation and establishment of the Special Taxing District. As pursuant to section 18-3(d), a public notice will be duly published in a newspaper of general circulation published in Miami-Dade County, Florida, and copies thereof will be mailed to all owners of taxable real property within the boundaries of the proposed Special Taxing District as their names and addresses appear on the latest Miami-Dade County Real Property Tax Roll.
Preliminary Public Meeting:	None necessary.
Required Referendum:	The creation of the Special Taxing District will be subject only to the Board’s approval; no election will be necessary as 100% of the property owners signed the petition.
Preliminary Assessment Roll:	Submitted on the same agenda as a separate agenda item for consideration and adoption by the Board and contingent upon the approval of this Special Taxing

District's creating Ordinance. The implementation of the assessment roll will be in accordance with the procedures defined in Chapter 18 of the Code.

Estimated Completion: Fall 2023

Estimated Initial Billing: November 2024. Assessment billed annually as an itemized portion of the Real Property tax bill.

	<u>First Year</u>	<u>Second Year</u>
Estimated Total District Costs:	\$8,627.53	\$290.98

Method of Apportionment: Front Footage

	<u>First Year</u>	<u>Second Year</u>
Estimated Annual District Assessments:		
Per Assessable Front Foot:	Costs to be	\$1.8773
For Tract A:	Provided by Petitioner	\$290.98

The above annual costs and assessment information are based on the expected lighting services to be provided by the Special Taxing District, and are subject to change in the event that the Special Taxing District's services are adjusted by the PROS Director as provided herein. Each subsequent year will be calculated based on actual cost.

State or federal grants are not applicable to this Special Taxing District.

Each Street Lighting Special Taxing District is unique due to its geographical boundaries, affected property owners, and level of service to be provided. Creation of a new Special Taxing District to provide this service is the best and most cost-effective method to achieve this benefit.

In accordance with the requirements of Chapter 28 of the Code to provide street lighting in new subdivisions through the creation of Street Lighting Special Taxing Districts, and in compliance with the provisions of section 18-3(c) of the Code, I have reviewed the facts submitted by PROS in its Report and Recommendations, a copy of which is attached and incorporated herein. I concur with their recommendation that this Special Taxing District be created pursuant to section 18-2 of the Code. Also, I recommend the provisions of Resolution No. R-130-06 be waived because adoption of this Ordinance is a precursor to the future execution of said agreement, which will not occur until development within the Special Taxing District occurs.



Jimmy Morales
Chief Operations Officer

**REPORT AND RECOMMENDATIONS
ON THE CREATION OF WEST LAKE SHOPPING CENTER
STREET LIGHTING SPECIAL TAXING DISTRICT
MIAMI-DADE COUNTY, FLORIDA**

Pursuant to Chapter 18 of the Code of Miami-Dade County (Code), and as a result of a detailed investigation of a duly petitioned for Special Taxing District, the following facts are submitted by the Miami-Dade County Parks, Recreation and Open Spaces Department (PROS) Director concerning the creation of West Lake Shopping Center Street Lighting Special Taxing District (Special Taxing District).

1. BOUNDARIES OF THIS DISTRICT

The proposed Special Taxing District is located entirely within a portion of Unincorporated Miami-Dade County, and the boundaries, as set forth in the petition, are as follows:

A portion of Section 18, Township 54 South, Range 40 East, Miami-Dade County, Florida (a.k.a. West Lake Shopping Center, Tentative Plat # T-24739); being more particularly described as follows:

The South 325.00 feet of the Southeast $\frac{1}{4}$ of the Southwest $\frac{1}{4}$ of the Southeast $\frac{1}{4}$ of Section 18, Township 54 South, Range 40 East, less Tract "A", Grossman Tract, according to the Plat thereof, as recorded in Plat Book 77 at Page 27 of the Public Records of Miami-Dade County, Florida, and less the West 125.00 feet of the South 175.00 feet thereof and less the East and West 25.00 feet and less the South 50.00 feet for road Right-of-Way, and also less a parcel of land now or formerly used for a lift station by Miami-Dade County described as: Commencing 50.00 feet north and 39.00 feet west of the Southeast corner of the Southwest $\frac{1}{4}$ of the Southeast $\frac{1}{4}$ of said Section 18, Township 54 South, Range 40 East, and running thence North 150.70 feet to the Point-of-Beginning of the following described parcel of land and running thence West 32.00 feet, thence North 15.00 feet, thence East 32.00 feet and thence South 15.00 feet to the Point-of-Beginning, all of said lands situate, lying and being in Miami-Dade County, Florida.

The Special Taxing District's boundaries and geographical location are shown on the attached sketch entitled West Lake Shopping Center Street Lighting Special Taxing District and hereinafter referred to as Exhibit A.

2. LOCATION OF THE INSTALLATIONS TO BE CONSTRUCTED

Services to be provided under the Special Taxing District will consist of public street lighting located within public rights-of-way.

3. ESTIMATED COSTS AND ANNUAL EXPENSE FOR MAINTENANCE, REPAIR AND OPERATION OF THIS DISTRICT

The cost of the streetlights in this Special Taxing District will be continual and is based on a preliminary estimate using Rate Schedule No. LT-1 prepared by Florida Power and Light (FPL) and approved by the Florida Public Service Commission, copies of which are attached. FPL will install

the lights, poles, and service lines at its expense and the facilities will remain the property of FPL. FPL will be responsible for the maintenance, repairs, upgrades, and replacement of the light standards, fixtures, lamps, and all connecting service lines. However, the developers, through the Special Taxing District, may be required to pay a differential cost if rapid construction techniques cannot be used on this Special Taxing District and this cost is shown in the Special Taxing District's cost estimate below.

<u>Estimated Annual District Costs</u>	<u>First Year</u>	<u>Second Year</u>
2 – 7,500 Lumens, 4000K LED Luminaires	\$198.48	\$198.48
Annual Fuel Adjustments (Based on (504 KWH at \$0.07443 per KWH)	\$37.51	\$37.51
Franchise Cost (Based on 9.2970% of \$235.99)	<u>\$21.94</u>	<u>\$21.94</u>
Total Street Lighting Service Costs	\$257.93	\$257.93
Engineering & Administrative Costs	\$6,009.02	\$9.02
Billing, Collecting, & Processing Costs	\$1,235.25	\$0.00
Contingencies	<u>\$1,125.33</u>	<u>\$24.03</u>
Total Costs Covered by Petitioner	\$8,627.53	
Total Costs to District		\$290.98
 <u>Estimated Annual District Assessments</u>	 <u>First Year</u>	 <u>Second Year</u>
Per Assessable Front Foot:	Costs to be	\$1.8773
For Tract A:	Provided by Petitioner	\$290.98

The above annual costs and assessment information are based on the expected lighting services to be provided by the Special Taxing District, and are subject to change in the event the Special Taxing District's services are adjusted by the Department Director. Total costs and assessments will be adjusted, if necessary, to meet actual costs.

4. CONFORMITY TO THE MASTER PLAN OF MIAMI-DADE COUNTY

The proposed Special Taxing District conforms to and in no way conflicts with the master plan of development for Miami-Dade County (County) (see attached memorandum from the Department of Regulatory and Economic Resources (RER)).

5. RECOMMENDATION CONCERNING THE DESIRABILITY OF THIS DISTRICT

The need for street lighting in the County is apparent. Residents and property owners of the County continue to demonstrate their desire for street lighting through numerous petitions and personal requests. The ability of the affected properties to pay special assessments is evident since

the costs of the Special Taxing District's services, including any bonds then outstanding, do not exceed 25% of the assessed valuation of all properties within the Special Taxing District's boundaries (including homesteads) as shown by the last preceding assessment roll of the County. In my opinion, the streetlights installed pursuant to the creation of this Special Taxing District will provide special benefits to properties within the Special Taxing District's boundaries exceeding the amount of special assessments to be levied.

6. PROCEDURE

As provided for under Chapter 18 of the Code, the property owners, the developers, within the proposed Special Taxing District shall guarantee payment of all costs and expenses incidental to the creation of such Special Taxing District and shall pay the entire cost of providing street lighting within the Special Taxing District for the first year. Based on front footage, each property owner within the proposed Special Taxing District will pay the County, through a special assessment, a proportionate share of the total annual costs for the second year and each year thereafter.

In the event actual second year costs are lower than the costs estimated herein, the Director of PROS shall adjust and decrease the front foot rate of assessment. In the event actual second year costs are higher than estimated herein, the front foot rate of the assessment shall not be increased prior to the Board of County Commissioners (Board) adopting a revised assessment roll.

Following the creation of the Special Taxing District by the Board, the petitioner's plat shall not be placed on a Commission agenda for approval prior to receipt of the payment from the developers for the first-year costs as specified in Item 3 above. Upon adoption of the petitioner's plat by the Board, the County may then enter into an agreement with FPL, in substantially the form attached herein, wherein the County will pay to FPL any costs associated with the streetlight installation and ongoing costs of service.

7. RECOMMENDATION

It is recommended that West Lake Shopping Center Street Lighting Special Taxing District be created pursuant to section 18-2 of the Code, which provides for the creation of special taxing districts for street lighting in new subdivisions. The creation of this Special Taxing District will be subject to Board approval only; no election will be necessary as 100% of the property owners signed the petition. I also recommend that the County Attorney cause to be prepared an ordinance authorizing the creation of the West Lake Shopping Center Street Lighting Special Taxing District. Pursuant to Chapter 18 of the Code, the Board shall receive and hear, at a public hearing, remarks by interested persons on this Special Taxing District, and thereafter may adopt such ordinance. Following adoption of the creating ordinance, it is further recommended that the Board adopt the Special Taxing District's Preliminary Assessment Roll resolution to fund the Special Taxing District's services. Adoption of this resolution will enable the Miami-Dade County Tax Collector to collect the funds necessary to administer the Special Taxing District, reimburse affected County Departments involved in the creation and establishment of the Special Taxing District, as well as provide funds for payment of the Special Taxing District's monthly power bills for the second year and each year thereafter. The ordinance creating the Special Taxing District shall take effect 10 days after the date of its adoption, unless vetoed by the Mayor, and if vetoed, it shall become effective only upon an override by the Board. My office will also be available to answer any questions from the public or your office in regard to the financial and/or engineering facts of this Special Taxing District. We further recommend that the County Mayor or County Mayor's designee forward the attached report to the Board after review and concurrence with our findings.

- Attachments:
- (1) Copy of Petition and Attachments
 - (2) Copies of FPL Rate Schedule No. LT-1
 - (3) Copy of FPL Street Lighting Agreement Form
 - (4) Copy of Memo from Department of Regulatory and Economic Resources
 - (5) District Boundaries and Geographical Location Sketch (Exhibit A)

**MIAMI-DADE COUNTY ATTORNEY'S OFFICE
M E M O R A N D U M**

TO: Liset Romero-Lopez
Chief, Special Assessment Districts Division

FROM: Daija Page Lifshitz *DPL*
Assistant County Attorney

DATE: September 22, 2022

SUBJECT: West Lake Shopping Center Street Lighting Special Taxing District

Please be advised that I have reviewed the above referenced petition and find it to be legally sufficient for street lighting purposes only.

Memorandum



Date: September 21, 2022

To: Basia Pruna, Deputy Clerk
Office of the Clerk of the Board
Attn: Shania Momplaisir

From: Liset Romero-Lopez, Chief *LRL*
Special Assessment Districts Division
Parks, Recreation and Open Spaces Department

Subject: West Lake Shopping Center
Street Lighting Special Taxing District

In reference to the subject petition, we hereby certify that, in compliance with Section 18-2 of the Miami-Dade County Code, this Department has verified the attached name against the records of the Office of the Property Appraiser, and has concluded that said petition relates to real property in a new subdivision and the signator is an owner and/or individual signing in his official capacity as representative of the owner of the property in question. We are therefore submitting the following information:

- | | | |
|----|--|-------------|
| 1. | Total number of parcels of land within district boundaries | <u>5</u> |
| 2. | Total number of owners of property within district boundaries | <u>1</u> |
| 3. | Total number of resident owners within district boundaries
(this is a new subdivision area) | <u>0</u> |
| 4. | Total number of signatures on the petition | <u>1</u> |
| 5. | Total number of owners or representatives signing the petition
in an official capacity | <u>1</u> |
| 6. | Percentage of owners or representatives signing the petition
in their official capacity | <u>100%</u> |

Pursuant to Section 18-2 of the Code, this is a valid petition.

By copy of this memorandum, I am forwarding this petition for review by the County Attorney for legal sufficiency.

Attachment

c: Ryan Carlin

MDC010

**MIAMI-DADE COUNTY
PARKS, RECREATION AND OPEN SPACES DEPARTMENT
SPECIAL ASSESSMENT DISTRICTS DIVISION**

Document Preparation
Date March 23, 2022

Departmental Acceptance Date
(Government Use Only)

PETITION FOR STREETLIGHTING SPECIAL TAXING DISTRICT

To the Board of County Commissioners of Miami-Dade County, Florida:

We, the undersigned property owner(s), do hereby petition Miami-Dade County, Florida, for the creation of the Special Taxing District(s) required by the respective plat(s) pursuant to Chapter 18 of the Code of Miami-Dade County, Florida, for any or all of the following: installation, operation and maintenance of sodium vapor streetlights or LED of an intensity of 16,000 up to 50,000 lumens, mounted on concrete, fiber glass or existing poles. The petitioned for district lies within that portion of the unincorporated area of Miami-Dade County more fully described on the attached Exhibit A.

Tentative Plat(s) Name(s) West Lake Shopping Center

It is understood and agreed that the boundaries of this district and the type and level of services to be provided by this district will be reviewed by the appropriate County authorities. It is also understood that the streetlights to be provided shall be in accordance with minimum standards and requirements set forth by the Miami-Dade County Parks, Recreation and Open Spaces Department.

OWNER'S NAME	OWNER'S ADDRESS	LEGAL DESCRIPTION OF PROPERTY	TAX FOLIO NUMBER
MMG Westlake, LLC,	9171 South Dixie Highway Pinecrest, FL 33156		30-4018 000 1252, 1253, -1255, -1256, 1260
a Florida limited liability company			
Martin Pico, Manager		MORE FULLY DESCRIBED ON THE ATTACHED "EXHIBIT A"	

STATE OF FLORIDA

COUNTY OF Miami-Dade

I HEREBY CERTIFY that on this day, before me, an officer duly qualified to take acknowledgments, personally appeared Martin Pico, the Manager of MMG Westlake, LLC, a Florida limited liability company

personally, known to me, or () who produced identification in the form of _____, and who executed the foregoing resolution and acknowledged before me that Martin Pico executed the same for the purposes herein expressed.

WITNESS my hand and official seal in the County and State last aforesaid



Notary Public, State of Florida
Expires: July 22, 2023

(SEAL)

DEPARTMENTAL ACCEPTANCE DATE
(GOVERNMENT USE ONLY)

EXHIBIT "A"

EXHIBIT A TO THE PETITION FOR THE PLAT KNOWN AS
West Lake Shopping Center DATED March 23, 2022 FOR THE
CREATION OF A STREET LIGHTING SPECIAL TAXING DISTRICT.

Legal Description:

Folio No.: 30-4018-000-1252, 30-4018-000-1253, 30-4018-000-1255, 30-4018-000-1256, 30-4018 000-1260

THE SOUTH 325 FEET OF THE SOUTHEAST 1/4 OF THE SOUTHWEST 1/4 OF THE SOUTHEAST 1/4 OF SECTION 18, TOWNSHIP 54 SOUTH, RANGE 40 EAST, LESS TRACT "A" GROSSMAN TRACT, ACCORDING TO THE PLAT THEREOF RECORDED IN PLAT BOOK 77 AT PAGE 27 OF THE PUBLIC RECORDS OF MIAMI DADE COUNTY, FLORIDA, AND LESS THE WEST 125 FEET OF THE SOUTH 175 FEET THEREOF AND LESS THE EAST AND WEST 25 FEET AND LESS THE SOUTH 50 FEET FOR ROAD RIGHT-OF WAY, AND ALSO LESS A PARCEL OF LAND NOW OR FORMERLY USED FOR A LIFT STATION BY MIAMI-DADE COUNTY DESCRIBED AS: COMMENCING 50 FEET NORTH AND 39 FEET WEST OF THE SOUTHEAST CORNER OF THE SOUTHWEST 1/4 OF THE SOUTHEAST 1/4 OF SAID SECTION 18, TOWNSHIP 54 SOUTH, RANGE 40 EAST, AND RUNNING THENCE NORTH 150.7 FEET TO THE POINT OF BEGINNING OF THE FOLLOWING DESCRIBED PARCEL OF LAND AND RUNNING THENCE WEST 32 FEET, THENCE NORTH 15 FEET, THENCE EAST 32 FEET AND THENCE SOUTH 15 FEET TO THE POINT OF BEGINNING, ALL OF SAID LANDS SITUATE, LYING AND BEING IN MIAMI DADE COUNTY, FLORIDA.



LED LIGHTING PILOTRATE SCHEDULE: LT-1AVAILABLE:

In specific territories served, upon request of the entity that has jurisdiction over the area being lighted. Contact FPL for available installation territories.

APPLICATION:

For the purpose of lighting streets whether public or private, roadways, and common areas, other than individual residential locations. This includes but is not limited to parking lots, homeowners association common areas, or parks.

TYPE OF INSTALLATION:

FPL-owned fixtures normally will be mounted on poles of FPL's existing distribution system and served from overhead wires. On request of the Customer, FPL will provide special poles or underground wires at the charges specified below. FPL, at its discretion, may offer the customer the option of FPL-owned fixtures attached to poles owned by the customer.

SERVICE:

Service includes energy from dusk each day until dawn the following day and maintenance of FPL-owned Lighting Systems. Maintenance includes replacement or repair of any circuit component to assure the facilities are operational and safe.

LIMITATION OF SERVICE:

Stand-by or resale service is not permitted hereunder.

CUSTOMER CONTRIBUTIONS:

A Contribution-in-Aid-of-Construction (CIAC) will be required for:

- a) the differential cost between employing rapid construction techniques in trenching, backfilling and pole installation work where no obstructions exist, and the added cost to overcome obstructions such as sprinkler systems, paved surfaces (such as sidewalks, curbs, gutters, and roadways), landscaping, sodding and other obstructions encountered along the Lighting System installation route, including repair and replacement. If the Customer elects to perform work such as trenching and restoration, they will be reimbursed by FPL with a credit (not to exceed the total CIAC cost) for the value of this work as determined by FPL;
- b) the installation cost of any new overhead distribution facilities and/or the cost of alterations to existing distribution facilities which are required in order to serve the Lighting System less four (4) times the additional annual non-fuel energy revenue generated by the installation or alteration of the Lighting System, plus where underground facilities are installed, the differential installation cost between underground and overhead distribution facilities.

These costs shall be paid by the Customer prior to the initiation of any construction work by FPL. The Customer shall also pay any additional costs associated with design modifications requested after the original estimate has been made.

(Continued on Sheet No. 8.736)

(Continued from Sheet No. 8.735)

REMOVAL OF FACILITIES:

If FPL owned Lighting facilities are removed either by Customer request or termination or breach of the agreement, the customer will pay the fixture, pole, and conductor charges for the period remaining on the currently active term of service plus the cost to remove the facilities. These charges do not apply to street light conversions from FPL owned facilities covered under SL-1 to FPL owned LED facilities under this tariff. In all cases, should the Customer request termination of the agreement, such termination will require written notice 90 days prior to the date of termination.

Conversion of FPL Owned Streetlights (SL-1 facilities) to LED:

For customers converting Street Lights as per FPL's SL-1 Street Lighting Tariff paying the LED Conversion Recovery charge, there will be no charges for the fixtures being removed. Any other charges for relocation or replacement of FPL owned facilities would still apply.

CHANGE IN FIXTURE SIZE OR TYPE:

At the Customer's request, the Company will upgrade to a higher level of illumination when the changes are consistent with good engineering practices. The customer will pay the original installed cost of the removed fixtures, less any salvage value and depreciation, plus removal costs and will receive a credit for 4 years additional revenue generated by the larger fixtures. If changes are required to the distribution system to support the larger lights, standard CIAC charges as described on sheet 8.735 will also apply. The Customer will pay the Company the net costs incurred in making other fixture changes. Customers converting HPSV fixtures to LED and paying the LED Conversion Recovery Charge will not be charged for the fixtures being removed, as noted in the preceding paragraph. In all cases where luminaires are replaced, the Customer will sign a new service agreement. Billing on the rate for the new luminaire or lamp size will begin as of the next regular billing date. A luminaire may be relocated at the Customer's request upon payment by the Customer of the full cost of removal and reinstallation.

MONTHLY RATES for LED Fixtures*:

Energy Tier	Charge	Fixture Tier									
		1	2	3	4	5	6	7	8	9	10
A	\$ -	1.50	4.50	7.50	10.50	13.50	16.50	19.50	22.50	25.50	28.50
B	\$ 0.20	1.70	4.70	7.70	10.70	13.70	16.70	19.70	22.70	25.70	28.70
C	\$ 0.40	1.90	4.90	7.90	10.90	13.90	16.90	19.90	22.90	25.90	28.90
D	\$ 0.60	2.10	5.10	8.10	11.10	14.10	17.10	20.10	23.10	26.10	29.10
E	\$ 0.80	2.30	5.30	8.30	11.30	14.30	17.30	20.30	23.30	26.30	29.30
F	\$ 1.00	2.50	5.50	8.50	11.50	14.50	17.50	20.50	23.50	26.50	29.50
G	\$ 1.20	2.70	5.70	8.70	11.70	14.70	17.70	20.70	23.70	26.70	29.70
H	\$ 1.40	2.90	5.90	8.90	11.90	14.90	17.90	20.90	23.90	26.90	29.90
I	\$ 1.60	3.10	6.10	9.10	12.10	15.10	18.10	21.10	24.10	27.10	30.10
J	\$ 1.80	3.30	6.30	9.30	12.30	15.30	18.30	21.30	24.30	27.30	30.30
K	\$ 2.00	3.50	6.50	9.50	12.50	15.50	18.50	21.50	24.50	27.50	30.50
L	\$ 2.20	3.70	6.70	9.70	12.70	15.70	18.70	21.70	24.70	27.70	30.70
M	\$ 2.40	3.90	6.90	9.90	12.90	15.90	18.90	21.90	24.90	27.90	30.90
N	\$ 2.60	4.10	7.10	10.10	13.10	16.10	19.10	22.10	25.10	28.10	31.10
O	\$ 2.80	4.30	7.30	10.30	13.30	16.30	19.30	22.30	25.30	28.30	31.30
P	\$ 3.00	4.50	7.50	10.50	13.50	16.50	19.50	22.50	25.50	28.50	31.50
Q	\$ 3.20	4.70	7.70	10.70	13.70	16.70	19.70	22.70	25.70	28.70	31.70
R	\$ 3.40	4.90	7.90	10.90	13.90	16.90	19.90	22.90	25.90	28.90	31.90
S	\$ 3.60	5.10	8.10	11.10	14.10	17.10	20.10	23.10	26.10	29.10	32.10
T	\$ 3.80	5.30	8.30	11.30	14.30	17.30	20.30	23.30	26.30	29.30	32.30

* Catalog of available fixtures and the assigned billing tier for each can be viewed at www.FPL.com/partner/builders/lighting.html

(Continued on Sheet No. 8.737)

(Continued from Sheet No. 8.736)

Maintenance per Fixture (FPL Owned Fixture and Pole)	\$1.82
Maintenance per Fixture for FPL Fixtures on Customer Pole	\$1.27
LED Conversion Recovery	\$1.03

Notes:

The non-fuel energy charge is 3.042¢ per kWh.
 Bills rendered based on "Total" charge. Unbundling of charges is not permitted.

Charges for other FPL-owned facilities:

Wood pole used only for the street lighting system	\$5.20
Standard Concrete pole used only for the street lighting system	\$7.11
Round Fiberglass pole used only for the street lighting system	\$8.42
Decorative Tall Fiberglass pole used only for the street lighting system	\$17.77
Decorative Concrete pole used only for the street lighting system	\$14.43
Underground conductors	4.026 ¢ per foot

SPECIAL PROVISIONS:

Where the Company provides poles other than those listed above, the monthly charges, as applicable shall be computed as follows:

Facilities Charge: 1.63% of the Company's average installed cost of the pole.

BILLING

During the initial installation period:
 Facilities in service for 15 days or less will not be billed;
 Facilities in service for 16 days or more will be billed for a full month.

WILLFUL DAMAGE:

Upon the second occurrence of willful damage to any FPL-owned facilities, the Customer will be responsible for the cost incurred for repair or replacement. If the lighting fixture is damaged, based on prior written instructions from the Customer, FPL will:

- a) If a commercially available and FPL approved device exists, install a protective shield. The Customer shall pay \$280.00 for the shield plus all associated costs. However, if the Customer chooses to have the shield installed before the second occurrence, the Customer shall only pay the cost of the shield; or
- b) Replace with a like unshielded fixture. For this, and each subsequent occurrence, the Customer shall pay the estimated costs of the replacement fixture; or
- c) Terminate service to the fixture. In this case, the lighting facilities will be removed from the field and from billing; the customer will pay the lighting facilities charges for the remaining period of the currently active term of service plus the cost to remove the facilities.

Option selection shall be made by the Customer in writing and apply to all fixtures which FPL has installed on the Customer's behalf on the same account. Selection changes may be made by the Customer at any time and will become effective ninety (90) days after written notice is received.

(Continued on Sheet No. 8.738)

(Continued from Sheet No. 8.737)

OTHER CHARGES

Conservation Charge	See Sheet No. 8.030.1
Capacity Payment Charge	See Sheet No. 8.030.1
Environmental Charge	See Sheet No. 8.030.1
Fuel Charge	See Sheet No. 8.030.1
Storm Charge	See Sheet No. 8.040
Franchise Fee	See Sheet No. 8.031
Tax Clause	See Sheet No. 8.031

SPECIAL CONDITIONS:

Customers whose lights are turned off during sea turtle nesting season will receive a credit equal to the fuel charges associated with the fixtures that are turned off.

TERM OF SERVICE:

Initial term of ten (10) years with automatic, successive five (5) year extensions unless terminated in writing by either FPL or the Customer at least ninety (90) days prior to the current term's expiration. Term of service begins upon execution of the LED Lighting Agreement.

RULES AND REGULATIONS:

Service under this schedule is subject to orders of governmental bodies having jurisdiction and to the currently effective "General Rules and Regulations for Electric Service" on file with the Florida Public Service Commission. In case of conflict between any provision of this schedule and said "General Rules and Regulations for Electric Service", the provision of this schedule shall apply.



FPL Account Number: _____

FPL Work Request Number: _____

LED LIGHTING AGREEMENT

In accordance with the following terms and conditions, _____ (hereinafter called the Customer), requests on this _____ day of _____, from FLORIDA POWER & LIGHT COMPANY (hereinafter called FPL), a corporation organized and existing under the laws of the State of Florida, the following installation or modification of lighting facilities at (general boundaries) _____ located in _____, Florida.

(a) Installation and/or removal of FPL-owned facilities described as follows:

<u>Poles</u>				
Pole Type	Existing Pole Count (A)	# Installed (B)	# Removed (C)	New Pole Count (A+B-C)
Wood				
Standard Concrete				
Standard Fiberglass				
Decorative Concrete				
Decorative F fiberglass				

<u>Underground Conductor</u>				
Type	Existing Footage (A)	Feet Installed (B)	Feet Removed (C)	New Footage (A+B-C)
Under Pavement		N/A ⁽¹⁾		
Not Under Pavement				

(1) All new conductor installed is in conduit and billed as Not Under Pavement

That, for and in consideration of the covenants set forth herein, the parties hereto covenant and agree as follows:

FPL AGREES:

1. To install or modify the lighting facilities described and identified above (hereinafter called the Lighting System), furnish to the Customer the electric energy necessary for the operation of the Lighting System, and furnish such other services as are specified in this Agreement, all in accordance with the terms of FPL's currently effective lighting rate schedule on file at the Florida Public Service Commission (FPSC) or any successive lighting rate schedule approved by the FPSC.

THE CUSTOMER AGREES:

2. To pay a contribution in the amount of \$_____ prior to FPL's initiating the requested installation or modification.
3. To purchase from FPL all of the electric energy used for the operation of the Lighting System.
4. To be responsible for paying, when due, all bills rendered by FPL pursuant to FPL's currently effective lighting rate schedule on file at the FPSC or any successive lighting rate schedule approved by the FPSC, for facilities and service provided in accordance with this agreement.
5. To provide access, final grading and, when requested, good and sufficient easements, suitable construction drawings showing the location of existing and proposed structures, identification of all non-FPL underground facilities within or near pole or trench locations, and appropriate plats necessary for planning the design and completing the construction of FPL facilities associated with the Lighting System.
6. To perform any clearing, compacting, removal of stumps or other obstructions that conflict with construction, and drainage of rights-of-way or easements required by FPL to accommodate the lighting facilities.

IT IS MUTUALLY AGREED THAT:

7. Modifications to the facilities provided by FPL under this agreement, other than for maintenance, may only be made through the execution of an additional lighting agreement delineating the modifications to be accomplished. Modification of FPL lighting facilities is defined as the following:
 - a. the addition of lighting facilities;
 - b. the removal of lighting facilities; and
 - c. the removal of lighting facilities and the replacement of such facilities with new facilities and/or additional facilities.

Modifications will be subject to the costs identified in FPL's currently effective lighting rate schedule on file at the FPSC, or any successive schedule approved by the FPSC.

8. Lighting facilities will only be installed in locations that meet all applicable clear zone right-of-way setback requirements.
9. FPL will, at the request of the Customer, relocate the lighting facilities covered by this agreement, if provided sufficient right-of-ways or easements to do so and locations requested are consistent with clear zone right-of-way setback requirements. The Customer shall be responsible for the payment of all costs associated with any such Customer-requested relocation of FPL lighting facilities. Payment shall be made by the Customer in advance of any relocation.
10. FPL may, at any time, substitute for any luminaire installed hereunder another luminaire which shall be of at least equal illuminating capacity and efficiency.
11. This Agreement shall be for a term of ten (10) years from the date of initiation of service, and, except as provided below, shall extend thereafter for further successive periods of five (5) years from the expiration of the initial ten (10) year term or from the expiration of any extension thereof. The date of initiation of service shall be defined as the date the first lights are energized and billing begins, not the date of this Agreement. This Agreement shall be extended automatically beyond the initial the (10) year term or any extension thereof, unless either party shall have given written notice to the other of its desire to terminate this Agreement. The written notice shall be by certified mail and shall be given not less than ninety (90) days before the expiration of the initial ten (10) year term, or any extension thereof.
12. In the event lighting facilities covered by this agreement are removed, either at the request of the Customer or through termination or breach of this Agreement, the Customer shall be responsible for paying to FPL an amount equal to the fixture, pole, and conductor charges for the period remaining on the currently active term of service plus the cost to remove the facilities.

13. Should the Customer fail to pay any bills due and rendered pursuant to this agreement or otherwise fail to perform the obligations contained in this Agreement, said obligations being material and going to the essence of this Agreement, FPL may cease to supply electric energy or service until the Customer has paid the bills due and rendered or has fully cured such other breach of this Agreement. Any failure of FPL to exercise its rights hereunder shall not be a waiver of its rights. It is understood, however, that such discontinuance of the supplying of electric energy or service shall not constitute a breach of this Agreement by FPL, nor shall it relieve the Customer of the obligation to perform any of the terms and conditions of this Agreement.
14. The obligation to furnish or purchase service shall be excused at any time that either party is prevented from complying with this Agreement by strikes, lockouts, fires, riots, acts of God, the public enemy, or by cause or causes not under the control of the party thus prevented from compliance, and FPL shall not have the obligation to furnish service if it is prevented from complying with this Agreement by reason of any partial, temporary or entire shut-down of service which, in the sole opinion of FPL, is reasonably necessary for the purpose of repairing or making more efficient all or any part of its generating or other electrical equipment.
15. **This Agreement supersedes all previous Agreements** or representations, either written, oral, or otherwise between the Customer and FPL, with respect to the facilities referenced herein and constitutes the entire Agreement between the parties. This Agreement does not create any rights or provide any remedies to third parties or create any additional duty, obligation or undertakings by FPL to third parties.
16. In the event of the sale of the real property upon which the facilities are installed, upon the written consent of FPL, this Agreement may be assigned by the Customer to the Purchaser. No assignment shall relieve the Customer from its obligations hereunder until such obligations have been assumed by the assignee and agreed to by FPL.
17. This Agreement shall inure to the benefit of, and be binding upon the successors and assigns of the Customer and FPL.
18. The lighting facilities shall remain the property of FPL in perpetuity.
19. This Agreement is subject to FPL's Electric Tariff, including, but not limited to, the General Rules and Regulations for Electric Service and the Rules of the FPSC, as they are now written, or as they may be hereafter revised, amended or supplemented. In the event of any conflict between the terms of this Agreement and the provisions of the FPL Electric Tariff or the FPSC Rules, the provisions of the Electric Tariff and FPSC Rules shall control, as they are now written, or as they may be hereafter revised, amended or supplemented.

IN WITNESS WHEREOF, the parties hereby caused this Agreement to be executed in triplicate by their duly authorized representatives to be effective as of the day and year first written above.

Charges and Terms Accepted:

<p style="text-align: center;">_____</p> <p style="text-align: center;">Customer (Print or type name of Organization)</p>	<p>FLORIDA POWER & LIGHT COMPANY</p>
<p>By: _____</p> <p style="text-align: center;">Signature (Authorized Representative)</p> <p>_____</p> <p style="text-align: center;">(Print or type name)</p>	<p>By: _____</p> <p style="text-align: center;">(Signature)</p> <p>_____</p> <p style="text-align: center;">(Print or type name)</p>
<p>Title: _____</p>	<p>Title: _____</p>

Memorandum



Date: September 16, 2020

To: Maria Nardi, Director
Department of Parks, Recreation and Open Spaces

From: Jack Osterholt, Deputy Mayor/Director
Department of Regulatory and Economic Resources

Subject: Street lighting, Maintenance of Landscape, Walls Adjacent to Double Frontage Lots, Entrance Features and Lakes – Special Taxing Districts

All tentative plats in the unincorporated area of Miami-Dade County submitted to the Development Services Division (Land Development Section) of the Regulatory and Economic Resources Department (RER), must comply with the special taxing districts requirements of the Miami-Dade County Code (the Code) including, but not limited to street lights, maintenance of landscape, walls adjacent to double frontage lots, entrance features and lakes. Final Plats will not be presented to the Board of County Commissioners for consideration until the applicable special taxing districts are created, and all fees have been paid. In that regard, to ensure expeditious processing, this Memorandum may serve, through September 30, 2021, as approval for certain future special taxing district application requests as being consistent with the intent and purpose of the adopted 2020-2030 Comprehensive Development Master Plan (CDMP). Capital Improvement Element Policy CIE-4A states: “Appropriate funding mechanisms will be adopted and applied by Miami-Dade County and the Miami-Dade County Public Schools in order to assure the fiscal resources to maintain acceptable levels of service. Such funding mechanisms may include special taxing districts, municipal taxing service units, local option taxes, user fees, local gas tax, general obligation bonds, impact fees, special purpose authorities, and others as appropriate and feasible” (Adopted Components as Amended through January 23, 2020, page IX-9). The provision for services over and above minimum for neighborhoods and communities may be accomplished through the special taxing district as may be prescribed by the Code.

The RER has no objection to a blanket approval with condition to establish future special taxing districts as limited to requests for street lighting, landscape maintenance, walls adjacent to double frontage lots and lake maintenance districts. The previously noted special taxing districts may be established on the condition that the RER Development Services Division review all landscape maintenance districts and lake maintenance districts for consistency with Landscape Code (Chapter 18A) Section 18A-6(L) Storm Water Retention/Detention Areas.

JO:LG:NK:JB:GR



DISTRICT BOUNDARIES

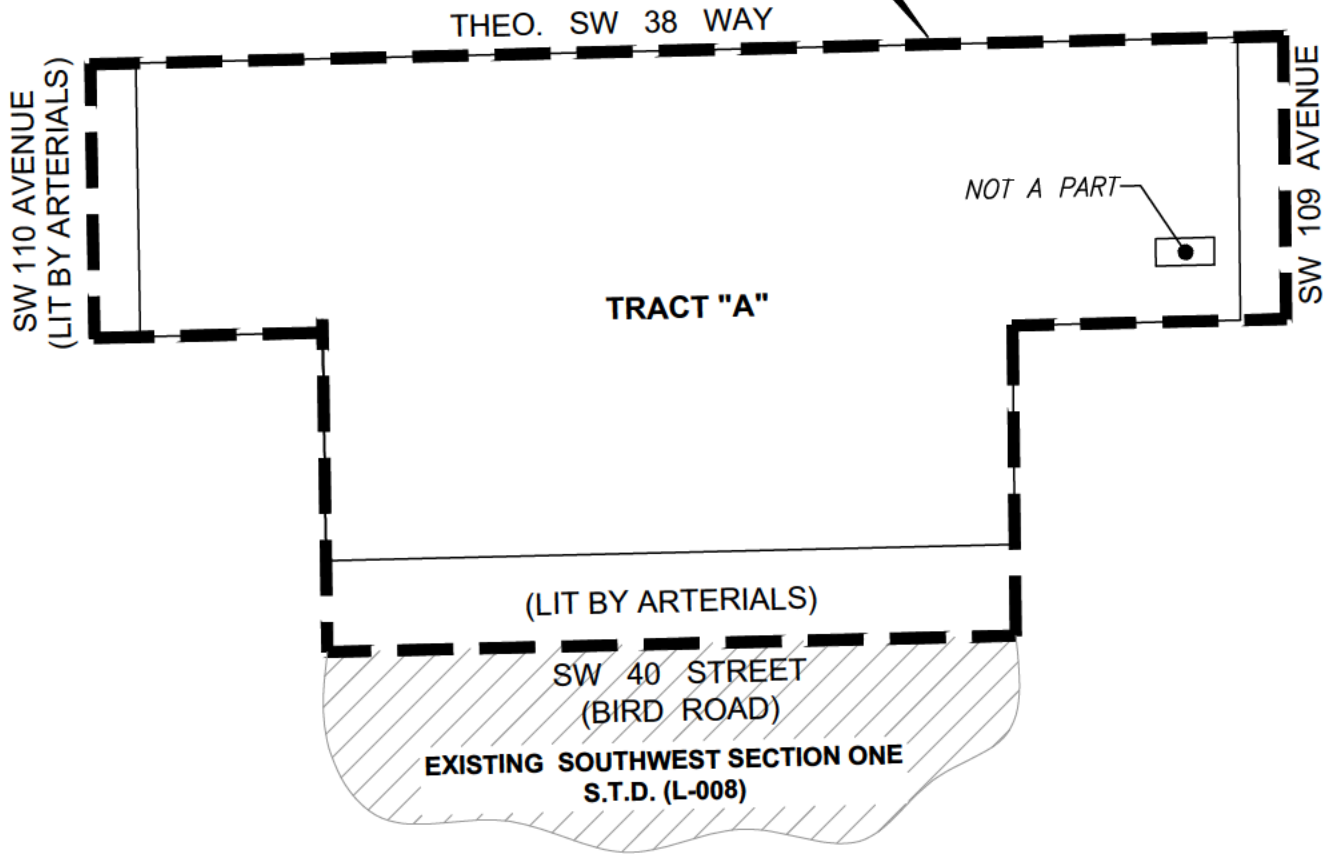

WEST LAKE SHOPPING CENTER STREET LIGHTING SPECIAL TAXING DISTRICT

2 - ROADWAY (7,500 LUMENS, 4000K) LED BRACKET-ARM
STREETLIGHTS MOUNTED ON EXISTING WOOD POLES.

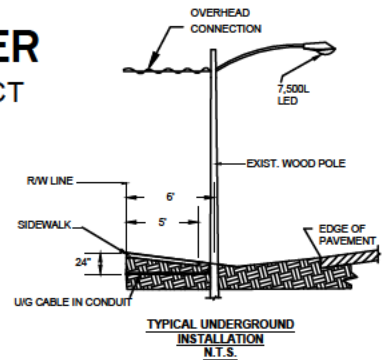

L-1483 (COMM. 0010)
SECTION: 18 - 54 - 40

EXHIBIT "A"
(BOUNDARIES & GEOGRAPHICAL LOCATION SKETCH)



MEMORANDUM
(Revised)

TO: Honorable Interim Chairman Oliver G. Gilbert, III
and Members, Board of County Commissioners

DATE: December 6, 2022

FROM: 
Gen Bonzon-Keenan
County Attorney

SUBJECT: Agenda Item No. 5(D)

Please note any items checked.

- "3-Day Rule" for committees applicable if raised
- 6 weeks required between first reading and public hearing
- 4 weeks notification to municipal officials required prior to public hearing
- Decreases revenues or increases expenditures without balancing budget
- Budget required
- Statement of fiscal impact required
- Statement of social equity required
- Ordinance creating a new board requires detailed County Mayor's report for public hearing
- No committee review
- Applicable legislation requires more than a majority vote (i.e., 2/3's present ____, 2/3 membership ____, 3/5's ____, unanimous ____, CDMP 7 vote requirement per 2-116.1(3)(h) or (4)(c) ____, CDMP 2/3 vote requirement per 2-116.1(3)(h) or (4)(c) ____, or CDMP 9 vote requirement per 2-116.1(4)(c)(2) ____) to approve
- Current information regarding funding source, index code and available balance, and available capacity (if debt is contemplated) required

Approved _____ Mayor
Veto _____
Override _____

Agenda Item No. 5(D)
12-6-22

ORDINANCE NO. _____

ORDINANCE CREATING AND ESTABLISHING A SPECIAL TAXING DISTRICT IN MIAMI-DADE COUNTY, FLORIDA, GENERALLY BOUNDED ON THE NORTH BY THEORETICAL SW 38 WAY, ON THE EAST BY SW 109 AVENUE, ON THE SOUTH BY SW 40 STREET (BIRD ROAD), AND ON THE WEST BY SW 110 AVENUE, KNOWN AND DESCRIBED AS WEST LAKE SHOPPING CENTER STREET LIGHTING SPECIAL TAXING DISTRICT; IDENTIFYING SERVICES TO BE PROVIDED; AUTHORIZING AND DIRECTING THE COUNTY MAYOR OR COUNTY MAYOR'S DESIGNEE TO PROVIDE FOR THE INSTALLATION OF STREETLIGHTS; APPROVING A STREET LIGHTING AGREEMENT WITH FLORIDA POWER AND LIGHT AND AUTHORIZING THE COUNTY MAYOR OR COUNTY MAYOR'S DESIGNEE TO EXECUTE THE AGREEMENT; WAIVING PROVISIONS OF RESOLUTION NO. R-130-06; AND PROVIDING FOR EXCLUSION FROM THE CODE AND AN EFFECTIVE DATE

WHEREAS, this Board desires to accomplish the purposes outlined in the accompanying memorandum, which is incorporated herein by reference; and

WHEREAS, a public hearing has been conducted by the Board of County Commissioners in accordance with the requirements and procedures of chapter 18 of the Code of Miami-Dade County,

BE IT ORDAINED BY THE BOARD OF COUNTY COMMISSIONERS OF MIAMI-DADE COUNTY, FLORIDA:

Section 1. This Board incorporates and approves the foregoing recitals as if fully set forth herein.

Section 2. In accordance with the provisions of chapter 18 of the Code, a special taxing district, to be known and designated as the West Lake Shopping Center Street Lighting Special Taxing District in Miami-Dade County, Florida, is hereby created and established in the unincorporated area of Miami-Dade County.

Section 3. The area or boundaries of this Special Taxing District, generally bounded on the north by theoretical SW 38 Way, on the east by SW 109 Avenue, on the south by SW 40 Street (Bird Road), and on the west by SW 110 Avenue, and located entirely within Commission District 10, are as follows:

A portion of Section 18, Township 54 South, Range 40 East, Miami-Dade County, Florida (a.k.a. West Lake Shopping Center, Tentative Plat # T-24739); being more particularly described as follows:

The South 325.00 feet of the Southeast $\frac{1}{4}$ of the Southwest $\frac{1}{4}$ of the Southeast $\frac{1}{4}$ of Section 18, Township 54 South, Range 40 East, less Tract "A", Grossman Tract, according to the Plat thereof, as recorded in Plat Book 77 at Page 27 of the Public Records of Miami-Dade County, Florida, and less the West 125.00 feet of the South 175.00 feet thereof and less the East and West 25.00 feet and less the South 50.00 feet for road Right-of-Way, and also less a parcel of land now or formerly used for a lift station by Miami-Dade County described as: Commencing 50.00 feet north and 39.00 feet west of the Southeast corner of the Southwest $\frac{1}{4}$ of the Southeast $\frac{1}{4}$ of said Section 18, Township 54 South, Range 40 East, and running thence North 150.70 feet to the Point-of-Beginning of the following described parcel of land and running thence West 32.00 feet, thence North 15.00 feet, thence East 32.00 feet and thence South 15.00 feet to the Point-of-Beginning, all of said lands situate, lying and being in Miami-Dade County, Florida.

The areas and geographical locations of this Special Taxing District are shown on the map or sketch, attached to the accompanying memorandum.

Section 4. The improvements and/or services to be provided in this Special Taxing District will consist of street lighting services within public rights-of-way, as described in the Report.

Section 5. The installation of such street lighting will be accomplished pursuant to an agreement between Miami-Dade County and Florida Power and Light. The expected costs of the installation and operation of the Special Taxing District's services, including maintenance, electricity, engineering, administration, billing, collection and processing, for the first year are provided by petitioners and estimated to be \$8,627.53. The expected costs of the Special Taxing District's services for the second year are estimated to be \$290.98. The expected estimated cost per assessable front foot of real property within the Special Taxing District for the second year is \$1.8773. The succeeding years' assessments will be adjusted based on actual costs.

Section 6. The entire cost of the Special Taxing District's improvements and/or services shall be specially assessed. It is hereby declared that said services will be a special benefit to all properties within the Special Taxing District and the total amount of special assessments to be levied as aforesaid will not be in excess of such special benefit.

Section 7. The proposed street lighting agreement between Miami-Dade County and Florida Power and Light is hereby approved and made a part hereof by reference. The provisions of Resolution No. R-130-06 are hereby waived because adoption of this Ordinance is a precursor to the future execution of said agreement, which will not occur until development within the Special Taxing District occurs.

Section 8. The County Mayor or County Mayor's designee is hereby authorized and directed to execute at the appropriate time the incorporated street lighting agreement, in substantially the form attached to the accompanying memorandum, for and on behalf of Miami-Dade County.

Section 9. The County Mayor or County Mayor's designee is authorized and directed to cause the installation of said streetlights to be accomplished within the Special Taxing District in accordance with the provisions of said agreement and the terms of this Ordinance.

Section 10. The County Mayor or County Mayor's designee is further directed to cause to be prepared and filed with the Clerk one Preliminary Assessment Roll for the street lighting services, in accordance with the provisions of sections 18-14 and 18-22.1 of the Code. As authorized by section 197.3632, Florida Statutes, all special assessments levied and imposed under the provisions of this Ordinance shall be collected, subject to the provisions of chapter 197, Florida Statutes, in the same manner and at the same time as ad valorem taxes. Unless paid when due, such assessments shall be deemed delinquent and payment thereof may be enforced by means of the procedures provided by the provisions of chapter 197, Florida Statutes, and section 18-14 of the Code, including possible loss of title.

Section 11. A duly certified copy of this Ordinance shall be filed in the Office of the Clerk of the Circuit Court of Miami-Dade County, Florida, and recorded in the appropriate book of records.

Section 12. It is the intention of this Board and it is hereby ordained that the provisions of this Ordinance shall be excluded from the Code.

Section 13. The provisions of this Ordinance shall become effective 10 days after the date of enactment, unless vetoed by the Mayor, and if vetoed, shall become effective only upon an override by this Board.

PASSED AND ADOPTED:

Approved by County Attorney as
to form and legal sufficiency:



Prepared by:



Daija Page Lifshitz