

Memorandum



Date: May 5, 2026

To: Honorable Chairman Anthony Rodriguez
and Members, Board of County Commissioners

Agenda Item No. 8(N)(7)

From: Daniella Levine Cava *Daniella Levine Cava*
Mayor

Subject: Resolution Authorizing Execution of a Tri-Party Agreement between Miami-Dade County, the Florida Department of Transportation and the South Florida Regional Transportation Authority for the Installation of Railroad Crossing Traffic Control Devices at NW 17th Avenue between NW 22nd Street and NW 23rd Street

Executive Summary

This item seeks approval of a resolution authorizing the Administration to execute a Tri-Party Railroad Reimbursement Agreement among Miami-Dade County (County), the Florida Department of Transportation (FDOT), and the South Florida Regional Transportation Authority (SFRTA) for the installation and upgrade of railroad grade crossing traffic control devices at NW 17th Avenue between NW 22nd Street and NW 23rd Street (Crossing No. 628424V) along the South Florida Rail Corridor. The project will replace and modernize railroad signal safety equipment, including new gate assemblies, flashing signals, control house equipment, power systems, and associated infrastructure to improve safety at the at-grade crossing.

There is no upfront capital cost to the County, as FDOT will reimburse SFRTA for 100 percent of the installation costs under the federal Signal Safety Program (23 U.S.C. §130). However, under the agreement, the County will assume ongoing financial responsibility for certain long-term costs, including a share of annual signal maintenance costs (generally 50 percent), and future reconstruction, relocation, or improvements requested by the County.

The agreement formalizes the County's participation in a state-led safety improvement project and establishes long-term operational and maintenance responsibilities following installation.

Recommendation

It is recommended that the Board of County Commissioners (Board) approve the attached resolution authorizing execution of a Tri-Party Agreement among Miami-Dade County, FDOT, and SFRTA for the installation and upgrade of railroad crossing traffic control devices at NW 17th Avenue between NW 22nd Street and NW 23rd Street.

Scope

The railroad crossing is located in Commission District 3, represented by Commissioner Keon Hardemon.

Fiscal Impact/Funding Source

There will be no fiscal impact to the County as SFRTA will be the agency responsible for the installation of the railroad signal safety equipment, and FDOT will reimburse it for 100 percent of the cost for the traffic control devices installed and upgraded. After installation, the County will assume certain ongoing obligations, including payment of approximately 50 percent of annual signal maintenance costs (subject to periodic revision under state rules), and responsibility for future reconstruction or upgrades initiated by the County or required due to roadway changes. Annual signal maintenance costs will be funded through Secondary Gas Tax funds.

Track Record/Monitor

The implementing County agency is the Department of Transportation and Public Works (DTPW), and the Project Manager responsible for monitoring this project is Nestor J. Melian, E.I.

Delegated Authority

In accordance with Section 2-8.3 of the Miami-Dade Code related to identifying delegation of Board authority, there are no authorities beyond that specified in the resolution which includes authority for the Mayor or Mayor's designee to execute the agreement on behalf of Miami-Dade County and to exercise the provisions contained therein.

Background

This project is part of a broader state and federally funded railroad safety initiative under the Federal Highway Administration's Railway-Highway Crossings Program (23 U.S.C. §130), which provides funding to enhance safety at public at-grade rail crossings. The improvements will be implemented along the South Florida Rail Corridor, a state-owned rail line managed and operated by SFRTA on behalf of FDOT. Under existing operating agreements, SFRTA is responsible for maintaining and operating rail infrastructure along the corridor, including signals and communications systems.

FDOT has identified the NW 17th Avenue crossing as a priority safety improvement project and is sponsoring the installation and upgrade of modern railroad traffic control devices at the location. Under the proposed agreement: (1) SFRTA will design and install the upgraded railroad crossing signals and related infrastructure; (2) FDOT will fully reimburse SFRTA for installation costs using federal safety funds; and (3) Miami-Dade County, as the roadway authority, must enter into the agreement to acknowledge its jurisdiction over the roadway and accept certain long-term responsibilities following project completion.

The agreement establishes that once the upgraded signals are installed: (1) SFRTA will continue operating and maintaining the railroad signal systems; (2) the County will share in ongoing maintenance costs and assume responsibility for roadway-related elements such as pavement markings and advance warning signage; and the County will bear financial responsibility for future modifications driven by roadway changes or County-initiated improvements.

Honorable Chairman Anthony Rodriguez
and Members, Board of County Commissioners
Page No. 3

The agreement is required to enable FDOT to proceed with the federally funded safety improvements and to formalize the respective roles and responsibilities of the state, regional rail operator, and local roadway authority.

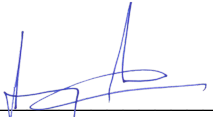

Jimmy Morales
Chief Operating Officer



MEMORANDUM
(Revised)

TO: Honorable Chairman Anthony Rodriguez
and Members, Board of County Commissioners

DATE: May 5, 2026

FROM: 
Cliff Bonzon-Keenan
County Attorney

SUBJECT: Agenda Item No. 8(N)(7)

Please note any items checked.

- _____ **“3-Day Rule” for committees applicable if raised**
- _____ **6 weeks required between first reading and public hearing**
- _____ **4 weeks notification to municipal officials required prior to public hearing**
- _____ **Decreases revenues or increases expenditures without balancing budget**
- _____ **Budget required**
- _____ **Statement of fiscal impact required**
- _____ **Statement of social equity required**
- _____ **Ordinance creating a new board requires detailed County Mayor’s report for public hearing**
- _____ **No committee review**
- _____ **Requires more than a majority vote (i.e., 2/3’s present ____, 2/3 membership ____, 3/5’s ____, unanimous ____, majority plus one ____, CDMP 7 votes (majority of membership) ____, CDMP 2/3 members present but not less than 7 votes (majority of membership) ____, CDMP 9 votes (2/3 membership) _____) to approve**
- _____ **Current information regarding funding source, index code and available balance, and available capacity (if debt is contemplated) required**

Approved _____ Mayor
Veto _____
Override _____

Agenda Item No. 8(N)(7)
5-5-26

RESOLUTION NO. _____

RESOLUTION APPROVING A TRI-PARTY AGREEMENT BETWEEN MIAMI-DADE COUNTY, THE STATE OF FLORIDA DEPARTMENT OF TRANSPORTATION AND THE SOUTH FLORIDA REGIONAL TRANSPORTATION AUTHORITY FOR THE INSTALLATION OF RAILROAD CROSSING TRAFFIC CONTROL DEVICES AT CROSSING NO. 628424V, ON NW 17TH AVENUE BETWEEN NW 22ND STREET AND NW 23RD STREET; AND AUTHORIZING THE COUNTY MAYOR OR COUNTY MAYOR'S DESIGNEE TO EXECUTE SAME AND EXERCISE PROVISIONS CONTAINED THEREIN

WHEREAS, this Board desires to accomplish the purposes outlined in the accompanying memorandum, a copy of which is incorporated herein by reference,

NOW, THEREFORE, BE IT RESOLVED BY THE BOARD OF COUNTY COMMISSIONERS OF MIAMI-DADE COUNTY, FLORIDA, that this Board approves the execution of a Tri-Party Agreement between Miami-Dade County, the State of Florida Department of Transportation, and the South Florida Regional Transportation Authority for the installation of railroad crossing traffic control devices at NW 17th Avenue between NW 22nd Street and NW 23rd Street, Railroad Crossing No. 628424V, in substantially the form attached hereto and made a part hereof, and authorizes the County Mayor or County Mayor's designee to execute same on behalf of Miami-Dade County and to exercise the provisions contained therein.

The foregoing resolution was offered by Commissioner _____, who moved its adoption. The motion was seconded by Commissioner _____ and upon being put to a vote, the vote was as follows:

Anthony Rodriguez, Chairman

Kionne L. McGhee, Vice Chairman

Marleine Bastien

Sen. René García

Roberto J. Gonzalez

Danielle Cohen Higgins

Natalie Milian Orbis

Micky Steinberg

Juan Carlos Bermudez

Oliver G. Gilbert, III

Keon Hardemon

Vicki L. Lopez

Raquel A. Regalado

The Chairperson thereupon declared this resolution duly passed and adopted this 5th day of May, 2026. This resolution shall become effective upon the earlier of (1) 10 days after the date of its adoption unless vetoed by the County Mayor, and if vetoed, shall become effective only upon an override by this Board, or (2) approval by the County Mayor of this resolution and the filing of this approval with the Clerk of the Board.

MIAMI-DADE COUNTY, FLORIDA
BY ITS BOARD OF
COUNTY COMMISSIONERS

JUAN FERNANDEZ-BARQUIN, CLERK

By: _____
Deputy Clerk

Approved by County Attorney as
to form and legal sufficiency.



Bruce Libhaber

**STATE OF FLORIDA DEPARTMENT OF TRANSPORTATION
RAILROAD REIMBURSEMENT AGREEMENT
GRADE CROSSING AND CROSSING TRAFFIC CONTROL DEVICES
SOUTH FLORIDA RAIL CORRIDOR ONLY
FEDERAL FUNDED PROJECTS ON OFF-SYSTEM ROADS COUNTY RR CROSSINGS ONLY**

Financial Project I.D.	Road Name or Number	County Name	Parcel & R/W Number	FAP Number
455412-1-57-01	NW 17 th Avenue	Miami-Dade	1(SIG-P)	

THIS AGREEMENT, made and entered into this _____ day of _____, _____ by and between the **STATE OF FLORIDA DEPARTMENT OF TRANSPORTATION**, hereinafter called the **DEPARTMENT**, and **MIAMI-DADE COUNTY**, a political subdivision of the State of Florida, acting by and through its Board of County Commissioners, hereinafter called the **COUNTY**, and the **SOUTH FLORIDA REGIONAL TRANSPORTATION AUTHORITY**, a body politic and corporate and an agency of the State of Florida created pursuant to Chapter 343, Florida Statutes, hereinafter called the **SFRTA**.

WITNESSETH:

WHEREAS, the **DEPARTMENT** and CSX Transportation, Inc., ("**CSXT**") entered into a contract for Installment Sale and Purchase, for the South Florida Rail Corridor ("**SFRC**") dated May 11, 1988, at which time the **DEPARTMENT** became the owner of said property and **CSXT** retained an exclusive perpetual easement for Rail Freight Operations within the **SFRC** upon which railroad freight, intercity passenger and commuter rail services are currently being conducted, and

WHEREAS, the **DEPARTMENT** and **CSXT** entered into an Operating and Management Agreement Phase A (OMAPA) pertaining to the line of railroad between West Palm Beach and Miami, Florida and related properties on May 11, 1988 (the "Phase A Agreement"), pursuant to which **CSXT** managed and maintained the **SFRC** property on behalf of the **DEPARTMENT** until March 28th, 2015, and

WHEREAS, the **DEPARTMENT** and **CSXT** entered into an Amended South Florida Operating and Management Agreement (SFOMA) on January 25th, 2013, as may be further amended, which provides for termination of OMAPA and transition of management, operation, and maintenance of the **SFRC** from **CSXT** to the **DEPARTMENT** upon the date determined pursuant to subsection 1(c) of SFOMA (the "SFOMA Commencement Date", which was March 29th, 2015), and

WHEREAS, the **DEPARTMENT** and the **SFRTA** entered into the **SFRC** Operating Agreement ("Operating Agreement") on June 13th, 2013, by which the **SFRTA** on behalf of the **DEPARTMENT**, has been managing, operating, maintaining, and dispatching, railroad operations on the **SFRC** as of the SFOMA Commencement

Date, and also maintains and repairs the rights-of-way, layover facilities and yards, state-owned buildings and facilities, tracks, bridges, communications, signals and all appurtenances on the SFRC, and

WHEREAS, the **DEPARTMENT** currently has a project underway, identified as 455412-1-57-01, and which encompasses a portion of the Public Road System at NW 17th Avenue (Project); and

WHEREAS, the **SFRTA**, at the request and sole cost and expense to the **DEPARTMENT**, is, constructing, reconstructing or otherwise changing a portion of the County road, which crosses at grade the right-of-way and track(s) of the SFRC at milepost SXD 39.03, FDOT/Association of American Railroads (AAR) Crossing Number 628424V, at or near MIAMI-DADE, Florida as shown on the Project Location Sheet EXHIBIT "A" – LOCATION MAP, attached hereto and made a part hereof, and

WHEREAS, the **COUNTY** is not a party to any of the aforementioned agreements and now agrees to enter into this Railroad Reimbursement Agreement ("Agreement") with the **DEPARTMENT** and **SFRTA**,

NOW, THEREFORE, in consideration of the mutual undertakings as set forth herein, the parties hereto agree as follows:

1. The **SFRTA** shall perform work based on the categories selected below, within the **DEPARTMENT**'s right-of-way along the SFRC, over its tracks at the above-referenced location, herein referred to as the ("Project").

(a) Surface Work

If crossing surface work is required for the Project, the **SFRTA**, shall provide, furnish or have furnished, all necessary material required for, and will construct at **DEPARTMENT**'s sole cost and expense a Standard Railroad Crossing Type -Choose A Type- in accordance with the **DEPARTMENT**'s Standard Plans for Road and Bridge Construction Index No. 830-T01 attached hereto and by this reference made a part hereof, and in accordance with all other Federal Railroad Administration (FRA) and American Railway Engineering and Maintenance of Way Association (AREMA) standards and guidelines. The initial construction cost shall be paid by the **DEPARTMENT** and the cost of any reconstruction or rehabilitation thereafter shall be paid by the **COUNTY**. In accordance with the Operating Agreement and the SFOMA Agreement, upon completion of the crossing, the SFRTA shall be responsible for the following:

1. Single Track crossing: routine maintenance of all trackbed and rail components plus the highway roadbed and surface for the width of the rail ties within the crossing area.

2. Multiple-track crossing: routine maintenance of all trackbed and rail components plus the highway roadbed and surface for the width of the rail ties within the crossing area and between tracks.

Routine maintenance includes but is not limited to regular track inspections and any repairs to the concrete panels or asphalt within the area described as **SFRTA's** responsibility. Upon completion of the crossing, the **COUNTY** shall be responsible for the maintenance of the highway roadbed and surface outside the railway ties. IT BEING EXPRESSLY UNDERSTOOD AND AGREED that if the **COUNTY** does not properly maintain the highway roadbed and surface outside the railroad ties, the **SFRTA** may, at its option and upon notification to the **COUNTY**, perform such maintenance work and bill the **COUNTY** directly for costs thus incurred. All costs required for any subsequent reconstruction or rehabilitation of the crossing, as may be requested by any of the parties to this Agreement, shall be the sole financial responsibility of the **COUNTY**. This provision shall be governed and reimbursed in accordance with the paragraphs as specified below.

(b) Signal Work (Non-US Code Title 23, Section 130)

If Railroad Grade Crossing Traffic Control Devices work is required for the Project, the **SFRTA**, shall provide, furnish or have furnished, all necessary material required for, and will install at the **DEPARTMENT's** expense, automatic railroad grade crossing traffic control devices at said location in accordance with the **DEPARTMENT's** Standard Plans for Road and Bridge Construction Index No. 509-070 and/or 509-100 attached hereto, the Operating Agreement, and the SFOMA Agreement. Upon completion of the Project, the **COUNTY** shall be responsible for any signal work thereafter. This provision shall be governed and reimbursed in accordance with the paragraphs as specified below.

(c) Signal Work (US Code Title 23, Section 130)

If traffic control devices are being installed/upgraded under the Signal Safety Program (US Code Title 23, Section 130), then the **DEPARTMENT** will reimburse **SFRTA** for 100% of the costs of installation/upgrades pursuant to the **DEPARTMENT's** Standard Plans for Road and Bridge Construction Index No. 509-070 and/or 509-100 attached hereto, the Operating Agreement, and the SFOMA Agreement. This provision shall be governed and reimbursed in accordance with the paragraphs as specified below.

These paragraphs are applicable to work specified in paragraph 1(a) and/or 1(b):

2. If the project is for surface work or signal work (Non-US Code Title 23, Section 130) as identified in paragraph 1(a) or 1(b) above; all labor, services, materials, and equipment furnished by **SFRTA** in carrying out work to be performed, shall be billed by **SFRTA** directly to the **DEPARTMENT**. Upon completion of the Project, the **COUNTY** shall be responsible for any surface or signal work thereafter.
3. The **DEPARTMENT** will reimburse **SFRTA** for the cost of watchmen or flagging service in the carrying out of work within or adjacent to the **SFRC**, or work requiring movement of equipment, employees or trucks across the **SFRC**, or when at times **SFRTA** and/or the **DEPARTMENT** agree that such a service is necessary. Upon completion of the Project, the **COUNTY** shall be responsible for all such work previously mentioned.
4. The **DEPARTMENT** hereby agrees to reimburse **SFRTA**, as detailed in this Agreement, for all costs incurred by it in the installation and/or adjustment of said facilities, in accordance with the provisions above. It is understood and agreed by and between the parties hereto that preliminary engineering costs incorporated within this Agreement shall also be subject to payment by the **DEPARTMENT**. Upon completion of the Project, the **COUNTY** shall be responsible for all such costs mentioned in this paragraph.
5. It is understood and agreed that, if the project, is at **COUNTY** expense, the **COUNTY** shall receive fair and adequate credit for any salvage as a result of the above adjustment work; otherwise, the **DEPARTMENT** shall receive the salvage credit.
6. Upon completion of the Project, the **SFRTA** shall, within one hundred eighty (180) days, furnish the **DEPARTMENT** with three (3) copies of its final and complete billing of all costs incurred in connection with the work performed hereunder, such statement to follow as closely as possible the order of items contained in the estimate attached hereto. The **DEPARTMENT** shall reimburse the **SFRTA** for its portion of all actual costs attributable to the Project subject to other provisions in this Agreement. The total for labor, overhead, travel expenses, transportation, equipment, material and supplies, handling costs, and other services shall be shown in such a manner as will permit ready comparison with the approved plans and estimates. Material shall be itemized where they represent major components of cost in the relocation following the pattern set out in the approved estimate as closely as possible. Salvage credits from recovered and replaced

permanent and recovered temporary materials shall be reported in said bills in relative position with the charge for the replacement or the original charge for temporary use.

The final billing shall show the description and site of the Project; the date on which the first work was performed, or, if preliminary engineering or right-of-way items are involved, the date on which the earliest item of billed expenses was incurred; the date on which the last work was performed or the last item of billed expenses was incurred; and the location where the records and accounts billed can be audited. Adequate reference shall be made in the billing to the **SFRTA's** records, accounts, and other relevant documents. All cost records and accounts shall be subject to audit by a representative of the **DEPARTMENT**. Upon receipt of invoices, prepared in accordance with the above reimbursement provisions, the **DEPARTMENT** agrees to reimburse the **SFRTA** in the amount of such actual costs approved by the **DEPARTMENT's** auditor.

These paragraphs are applicable to work specified in paragraph 1(c):

7. If the Project is for Signal Safety improvements under Title 23, Section 130, as identified in Paragraph 1c, above; then the **DEPARTMENT** agrees to reimburse **SFRTA** for all costs incurred for the installation and/or adjustment of said Project in accordance with the provisions herein.
8. All labor, services, materials, and equipment furnished by **SFRTA** in carrying out work to be performed, shall be billed by **SFRTA** directly to the **DEPARTMENT**. Separate records as to costs of contract bid terms and force account items performed by **SFRTA** shall also be furnished by **SFRTA** to the **DEPARTMENT**.

These paragraphs are applicable to any type of work specified (paragraph 1(a), 1(b), or 1(c)):

9. Upon completion of the work, the **SFRTA** shall, within one hundred eighty (180) days, furnish the **DEPARTMENT** with three (3) copies of its final and complete billing of all costs incurred in connection with the work performed hereunder, such statement to follow as closely as possible the order of items contained in the estimate attached hereto. The **DEPARTMENT** shall reimburse the **SFRTA** for its portion of all actual costs attributable to the Project subject to other provisions in this Agreement. The total for labor, overhead, travel expenses, transportation, equipment, material and supplies, handling costs, and other services shall be shown in such a manner as will permit ready comparison with the approved plans and estimates. Material shall be itemized where they represent major components of cost in the relocation following the pattern set out in the approved estimate as closely as possible. Salvage credits from recovered and replaced

permanent and recovered temporary materials shall be reported in said bills in relative position with the charge for the replacement or the original charge for temporary use.

The final billing shall show the description and site of the Project; the date on which the first work was performed, or, if preliminary engineering or right-of-way items are involved, the date on which the earliest item of billed expenses was incurred; the date on which the last work was performed or the last item of billed expenses was incurred; and the location where the records and accounts billed can be audited. Adequate reference shall be made in the billing to the **SFRTA's** records, accounts, and other relevant documents. All cost records and accounts shall be subject to audit by a representative of the **DEPARTMENT**. Upon receipt of invoices, prepared in accordance with the above reimbursement provisions, the **DEPARTMENT** agrees to reimburse the **SFRTA** in the amount of such actual costs approved by the **DEPARTMENT's** auditor.

10. In accordance with Section 215.422 Florida Statutes, the following provisions are in this Agreement:

Contractors providing goods and services to the **DEPARTMENT** should be aware of the following time frames. Upon receipt, the **DEPARTMENT** has five (5) working days to inspect and approve the goods and services, unless the Agreement specifies otherwise. The **DEPARTMENT** has twenty (20) working days to deliver a request for payment (voucher) to the Department of Banking and Finance. The twenty (20) days are measured from the latter of the date the invoice is received or the date the goods or services are received, inspected, and approved.

If a payment is not available, within forty (40) days, a separate interest penalty at a rate as established pursuant to Section 215.422 (3)(b), Florida Statutes, will be due and payable in addition to the invoice amount, to the Contractor. Interest penalties of less than one (1) dollar will not be enforced unless the Contractor requests payment. Invoices, which have to be returned to a Contractor because of Contractor preparation errors, will result in a delay in the payment. The invoice payment requirements do not start until a properly completed invoice is provided to the **DEPARTMENT**.

A Vendor Ombudsman has been established within the Department of Bank and Finance. The duties of the individual include acting as an advocate for contractors/vendors who may be experiencing problems in obtaining timely payment(s) from a state agency. The Vendor Ombudsman may be contacted at (850) 413-5516, or by calling the Division of Consumer Services at 1-877-693-5236.

11. Payment shall be made only after receipt and approval of goods and services unless advance payments are authorized by the **DEPARTMENT**'s Comptroller under Section 334.44(29), F.S., or by the Department of Financial Services under Section 215.422(14), F.S.
12. In accordance with Section 287.058 F.S., the following provisions are in this Agreement: If this contract involves units of deliverables, then such units must be received and accepted in writing by the Contract Manager prior to payments. Bills for fees or other compensation for services or expenses shall be submitted in detail sufficient for a proper pre-audit and post-audit thereof.
13. Bills for travel expenses specifically authorized in this Agreement shall be submitted and paid in accordance with **DEPARTMENT** Rule 14-57.011, Florida Administrative Code, and the Federal Highway Administration Federal Aid Policy Guide, 23 C.F.R. Subchapter B, Part 140, Subpart I "Reimbursement for Railroad Work."
14. In the event this contract is for services in excess of TWENTY-FIVE THOUSAND DOLLARS (\$25,000.00) and a term of more than one year, the provisions of Section 339.135 (6)(a), Florida Statutes are hereby incorporated;

The **DEPARTMENT**'s obligation to pay under this contract is contingent upon an annual appropriation by the Florida Legislature in accordance with Section 287.0582, Florida Statutes.

The **DEPARTMENT** during any fiscal year, shall not expend money, incur any liability, or enter into any contract which, by its terms, involves the expenditures of money in excess of the amounts budgeted as available for expenditure during such fiscal year. Any contract, verbal or written, made in violation of this subsection is null and void, and no money may be paid on such contract. The **DEPARTMENT** shall require a statement from the Comptroller of the **DEPARTMENT** that such funds are available prior to the entering into any such contract or other binding commitment of funds.

Nothing herein contained shall prevent the making of contracts for periods, exceeding one year, but any contract so made shall be executory only for the value of the services to be rendered or agreed to be paid for in succeeding fiscal years, and this paragraph shall be incorporated verbatim in all contracts of the **DEPARTMENT** which are for an amount in excess of TWENTY-FIVE THOUSAND DOLLARS (\$25,000.00) and which have a term for a period of more than one year.

15. In accordance with Section 287.133 (2)(a), Florida Statutes, the following provisions are included in this Agreement:
- A person or affiliate who has been placed on the convicted vendor list following a conviction for a public entity crime may not submit a bid on a contract to provide any goods or services to a public entity, may not submit a bid on a contract with a public entity for the construction or repair of a public building or public work, may not submit bids, proposals, or replies on leases for real property to a public entity; may not be awarded or perform work as a contractor, supplier, subcontractor, or consultant under a contract with any public entity; and may not transact business with any public entity in excess of the threshold amount provided in section 287.017 for CATEGORY TWO for a period of 36 months from the date of being placed on the convicted vendor list.
16. In accordance with Section 287.134(2)(a), Florida Statutes, the following provisions are included in this agreement:
- An entity or affiliate who has been placed on the discriminatory vendor list may not submit a bid, proposal, or reply on a contract to provide any goods or services to a public entity; may not submit a bid, proposal, or reply on a contract with a public entity for the construction or repair of a public building or public work; may not submit bids, proposals, or replies on leases of real property to a public entity; may not be awarded or perform work as a contractor, supplier, subcontractor, or consultant under a contract with any public entity; and may not transact business with any public entity.
17. The cost of maintaining all signals at the crossing shall be allocated as follows; fifty percent (50%) of the expense thereof in maintaining the same shall be borne by the **COUNTY**, and fifty percent (50%) of the cost shall be borne by the **SFRTA**, as enumerated by the Schedule of Annual Cost of Automatic Highway Grade Crossing Traffic Control Devices attached hereto and by this reference made a part hereof and subject to future revision. Actual funding for the signals has been provided for in the Operating Agreement. **COUNTY** shall submit its 50% of the cost of the Annual Maintenance costs to the **DEPARTMENT**. In instances where signals are installed and/or adjusted pursuant to this Agreement and found to be in satisfactory working order by the parties hereto, the same shall be immediately put in service, operated and maintained by the **SFRTA** pursuant to the Operating Agreement and the SFOMA Agreement so long as **SFRTA** or successors or assigns shall operate the said signals at said grade crossing; or until it is agreed between the parties hereto that the signals are no longer necessary; or until the said crossing is abandoned; or legal requirements occur which shall cease operation of those signals. The **SFRTA** agrees that any future relocation or adjustment of said signals shall be performed by the **SFRTA**,

- but at the expense of the party initiating such relocation. Upon relocation, the maintenance responsibility shall be in accordance with the provisions of this Agreement. It is further agreed that the cost of maintaining any additional or replacement signal equipment at the same location will be shared as provided above.
18. Unless otherwise agreed upon herein, the **DEPARTMENT** agrees to ensure that the advance warning signs and railroad crossing pavement markings will conform to the Department of Transportation Manual on Uniform Traffic Control Devices (MUTCD) within 30 days of notification that the railroad signal improvements have been completed and that such signs and pavement markings will be continually maintained in conformance with the MUTCD as applicable. Upon completion of the Project, the **COUNTY** shall be responsible for the maintenance of all advance warning signs and railroad crossing pavement markings.
 19. The **DEPARTMENT** at its discretion, may arrange for the synchronization of the railroad crossing devices with existing or proposed highway traffic control devices at **NW 22nd STREET AND/OR NW 23RD STREET**. Neither of the parties shall disconnect the interconnection circuit or change or cause to be changed the signal sequence without prior notice to the other parties. Each party shall maintain its respective devices from the point of the junction box as provided for the interconnect cable.
 20. All work contemplated at this crossing shall at all times be subject to the approvals, obligations, and notice provisions pursuant to the Operating Agreement and the SFOMA Agreement.
 21. All contractors working in the SFRC are required to have Railroad Protective Public Liability and Railroad Protective Property Damage Liability insurance where the **DEPARTMENT**, **SFRTA**, and **CSXT** are named insureds, and with limits not less than **\$ 2,000,000.00** combined single limit for bodily injury and/or property damage per occurrence and with an annual aggregate limit of no less than **\$ 6,000,000.00** Contractor will furnish the **DEPARTMENT** and **SFRTA** a Certificate of Insurance showing that the contractor carries liability insurance (applicable to the job in question) in the amounts set forth above. Such insurance is to conform with the requirements of the U.S. Department of Transportation, Federal Highway Administration, Federal Aid Policy Guide, Subchapter G, Part 646, Subpart A, and any supplements thereto or revisions thereof.
 22. **SFRTA** hereby agrees, as applicable, to install and/or adjust the necessary parts of the SFRC facilities in accordance with the provisions set forth in the:

- (A) **DEPARTMENT** Procedure 725-080-002 Appendix D.4 and Rule 14-57.011 "Public Railroad-Highway Grade Crossing Costs", Florida Administrative Code,
- (B) Federal Highway Administration's Federal Aid-Highway Policy Guide, 23 C.F.R. Subchapter B, Part 140, Subpart I; and 23 C.F.R. Subchapter G, Part 646, Subpart B,

and any supplements thereto or revisions thereof, which, by reference hereto, are made a part hereof. **SFRTA** further agrees to do all such work with its own forces or by a contractor paid under a contract held by **SFRTA** under the supervision and approval of the **DEPARTMENT**, and the Federal Highway Administration, when applicable.

23. Attached hereto, and by this reference made a part hereof, are plans and specifications of the work to be performed by **SFRTA** pursuant to the terms hereof, and an estimate of the costs thereof in the amount of **\$ 659,482.00**. All work performed by the **SFRTA** pursuant hereto, shall be performed according to these plans and specifications as approved by the **DEPARTMENT**, and the Federal Highway Administration, if federal aid participating; and all subsequent plan changes shall likewise be approved by the **DEPARTMENT** and the Federal Highway Administration, when applicable.
24. The **DEPARTMENT** has determined that the method to be used by the **SFRTA** in developing future relocation or installation cost shall be actual and related indirect costs accumulated in accordance with a work order accounting procedure prescribed by the applicable Federal or State regulatory body.
25. The **DEPARTMENT** reserves the right to unilaterally cancel this agreement for refusal by the **COUNTY** or **SFRTA** to allow public access to all documents, or other material subject to the provisions of Chapter 119, Florida Statutes.
26. Should the use of said crossing be abandoned due to removal of the roadway then all rights hereby granted to the **COUNTY** shall thereupon cease and terminate and the **COUNTY** will, at its sole cost and in a manner satisfactory to the **SFRTA** and the **DEPARTMENT**, remove said crossing and restore the **SFRC** property to the condition previously found, provided that the **SFRTA** may, at its option, remove the said crossing and restore its property, and the **COUNTY**

will, in such event, upon bill rendered, pay to the **SFRTA** the entire cost incurred by it in such removal and restoration.

27. Upon execution, this Agreement shall supersede all provisions, relating to said crossing contained in any previous agreements and shall become the permanent agreement of record.
28. **SFRTA** shall:
 1. Utilize the U.S. Department of Homeland Security's E-Verify system to verify the employment eligibility of all new employees hired by the parties during the term of the contract; and
 2. Expressly require any subcontractors performing work or providing services pursuant to the state contract to likewise utilize the U.S. Department of Homeland Security's E-Verify system to verify the employment eligibility of all new employees hired by the subcontractor during the contract term.
29. **SFRTA** or its contractor shall use steel and iron manufactured in the United States, in accordance with the Buy America provisions of 23 CFR 635.410, as amended. Ensure that all manufacturing processes for this material occur in the United States. As used in this paragraph, a manufacturing process is any process that modifies the chemical content, physical shape or size, or final finish of a product, beginning with the initial melting and continuing through the final shaping and coating. If a steel or iron product is taken outside the United States for any manufacturing process, it becomes foreign source material. When using steel or iron materials as a component of any manufactured product (e.g., concrete pipe, prestressed beams, corrugated steel pipe, etc.), these same provisions apply. Foreign steel and iron may be used when the total actual cost of such foreign materials does not exceed 0.1% of the total Contract amount or \$2,500, whichever is greater. These requirements are applicable to all steel and iron materials incorporated into the finished work but are not applicable to steel and iron items that the **SFRTA** uses but does not incorporate into the finished work. Submit a certification from the manufacturer of steel or iron, or any product containing steel or iron, stating that all steel or iron furnished or incorporated into the furnished product was produced and manufactured in the United States or a statement that the product was produced within the United States except for minimal quantities of foreign steel and iron valued at \$ (actual cost). Submit each such certification to the **SFRTA** and the **DEPARTMENT** prior to incorporating the material or product into the project. Prior to the use of foreign steel or iron materials on a project, submit invoices to document the actual cost of such material; and **SFRTA** must grant written approval prior to incorporating the material into the project; and

30. **SFRTA** shall Comply with all the requirements imposed by Title VI of the Civil Rights Act of 1964, the regulations of the U.S. Department of Transportation issued thereunder, and the assurance by the **SFRTA** pursuant thereto. The **SFRTA** shall include the attached Title VI / Nondiscrimination Assurance in all contracts with consultants and contractors performing work on the Project that ensure compliance with Title VI of the Civil Rights Act of 1964, 49 C.F.R. Part 21, and related statutes and regulations.
31. It is understood and agreed by the parties to this Agreement that if any part, term, or provision of this Agreement is held illegal by the courts or in conflict with any law of the State of Florida, the validity of the remaining portions or provisions shall not be affected, and the rights and obligations of the parties shall be construed and enforced as if the Agreement did not contain the particular part, term, or provision held to be invalid.
32. Any questions or matters arising under this Agreement as to validity, construction, enforcement, performance, or otherwise, shall be determined in accordance with the laws of the State of Florida. Venue for any action arising out of or in any way related to this Agreement shall lie exclusively in a state court of appropriate jurisdiction.
33. The parties agree to bear their own attorney's fees and costs with respect to this Agreement.
34. The parties agree that this Agreement is binding on the parties and their assigns and successors in interest as evidenced by their signatures and lawful executions below.
35. A modification or waiver of any of the provisions of this Agreement shall be effective only if made in writing and executed with the same formality as this Agreement.
36. If the Operating Agreement between the **DEPARTMENT** and the **SFRTA** ceases to exist, the responsibilities of **SFRTA** may be assigned to a party operating the railroad.

IN WITNESS WHEREOF, the parties hereto have caused this Agreement to be executed by their respective and duly authorized officers the day and year first written above.

SFRTA

South Florida Regional Transportation Authority, A body politic and corporate and an agency of the State of Florida

By: David W. Dech 1/28/2026
SFRTA Executive Director

Approved as to form and legal sufficiency

By: Teresa Moon
SFRTA General Counsel

DEPARTMENT

State of Florida, Department of Transportation,
An Agency of the State of Florida

By: _____
Director of Transportation Development

Legal Review (DEPARTMENT):

By: _____

COUNTY

Attest:

**MIAMI-DADE COUNTY
BOARD OF COUNTY COMMISSIONERS**

By: _____

Date: _____

**APPROVED AS TO FORM
AND LEGAL SUFFICIENCY**

By: _____
County Attorney

Date: _____

EXHIBIT "A" – LOCATION MAP

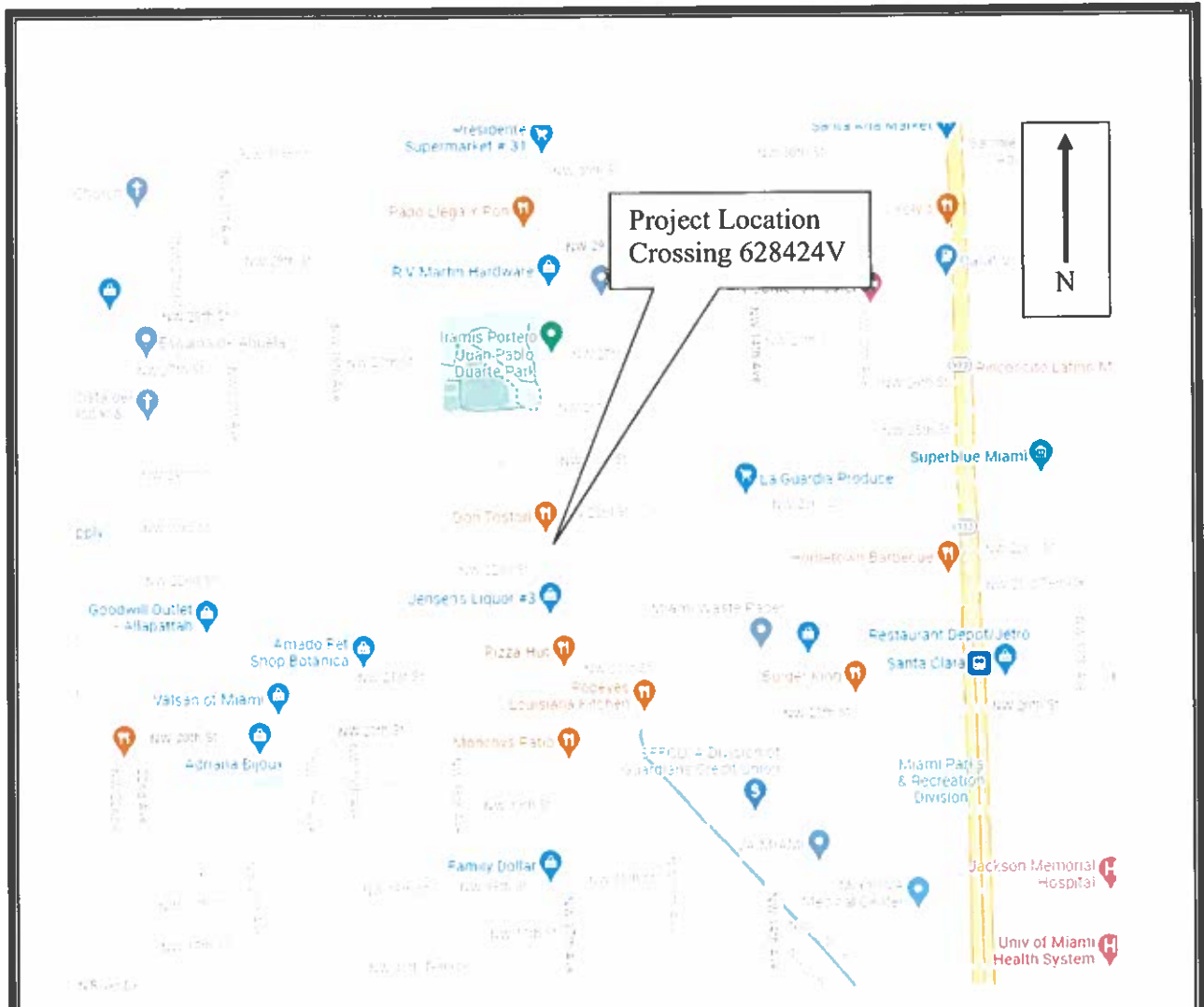

LOCATION MAP

South Florida Regional Transportation Authority (SFRTA)

LOCATION:	NW 17 th Avenue, Miami-Dade County
FINANCIAL PROJECT NO.:	455412-1-57-01
CROSSING NO.:	628424V
RAILROAD MILEPOST:	SXD 39.03

WORK DESCRIPTION GRADE CROSSING TRAFFIC CONTROL DEVICES

FINANCIAL PROJECT NO.	ROAD NAME OR NUMBER	COUNTY NAME	PARCEL & R/W NUMBER	FAP NUMBER
455412-1-57-01	NW 17 th Avenue	MIAMI-DADE	I(SIG-P)	

RAILROAD COMPANY

SFRTA

- A. **JOB DESCRIPTION & LOCATION:** Replace all equipments. 6X6 House and all the equipment (CWT, etc) - 2 new vehicle gate assemblies (Gates /LEDs / Bells) - Batteries - Service Pole - Cables - Fall Protection System to the Cantilever.
- B. **TYPE OF ROADWAY FACILITY:** Two-Way Street - 2 Thru lanes - Urban Local Access
- C. **FDOT/AAR XING NO.:** 628424V **RR MILE POST TIE:** SXD 39.03
- D. **TYPE CROSSING PROPOSED:** IV **Class:** III **DOT INDEX:** 509-070
- E. **STATUS AND PROPOSAL:**
1. **EXISTING DEVICES** (See Agreement dated _____)
 - a. None-New Crossing.
 - b. Crossbuck and Disk
 - c. Flashing Signals with Disk
 - d. Flashing Signals with Cantilever
 - e. Flashing Signals with Gates
 - f. Flashing Signals with Cantilever and Gates
 2. **PROPOSED DEVICES** (Safety Index Rating 1932)
 - a. No revision required
 - b. Crossbuck and Disk
 - c. Flashing Signals and Disk
 - d. Flashing Signals with Cantilever
 - e. Flashing Signals with Gates.
 - f. Flashing Signals with Cantilever and Gates.
 - g. Relocate existing signal devices
 - (1) (With-Without) addition of Gates
 - (2) ((With-Without) synchronization with highway traffic signals
 - (3) ((With-Without) constant warning time
- F. **COMMUNICATION AND/OR POWER LINE ADJUSTMENTS**
1. By Others (_____ Company.)
 2. By Railroad Company.
- G. **AUTHORITY REQUESTED** (Draft attached: Yes No)
1. Agreement (Third Party Participating Miami-Dade County, SFRTA and FDOT)
 2. Supplemental Agreement No. _____
 3. Crossing Permit
 4. Estimate for Change Order No. _____
 5. Letter of Authority
 6. Letter of confirmation (No Cost to Department)
- H. **OTHER REMARKS:** Negotiations to be completed by: _____

Negotiations to be completed by: _____

Signal installation target date: _____

Synchronization: (Draft attached: Yes No)

EXHIBIT B

The Company shall:

1. adhere to all Buy America requirements (23 CFR 635.410) to ensure that all manufacturing processes of steel and iron occur in the United States; and
2. ensure that prefabricated items that contain steel must also comply with Buy America; and
3. provide Buy America certifications that include correct language, project information, and the material's delivery date.

EXHIBIT C

The Company understands:

1. that while FHWA1273 does not apply to force account work performed by rail companies, FHWA-assistance is subject to Title VI (42 U.S.C. § 2000d et seq); and
2. requires appropriate assurances by providing an executed Title VI / Nondiscrimination Assurance, including Appendices A and E.

STATE OF FLORIDA DEPARTMENT OF TRANSPORTATION
RAILROAD GRADE CROSSING TRAFFIC CONTROL DEVICES
ANNUAL MAINTENANCE COSTS

725-090-41
 RAIL
 06/21

FINANCIAL PROJECT NO.	ROAD NAME OR NUMBER	COUNTY NAME	PARCEL & R/W NUMBER	FAP NUMBER
455412-1-57-01	NW 17 th Avenue	MIAMI-DADE	I(SIG-P)	

COMPANY NAME: SOUTH FLORIDA REGIONAL TRANSPORTATION AUTHORITY (SFRTA)

A. FDOT/AAR XING NO.: 628424V RR MILE POST TIE: SXD 39.03

B. TYPE SIGNALS PROPOSED: IV CLASS: III

C. DOT INDEX: 509-070

**SCHEDULE OF ANNUAL COST OF AUTOMATIC
 HIGHWAY GRADE CROSSING TRAFFIC CONTROL DEVICES**

Annual Maintenance Cost Exclusive of Installation

<u>CLASS</u>	<u>DESCRIPTION</u>	<u>COST*</u>
I	2-Quadrant Flashing Lights with One Track	\$2,608.00
II	2-Quadrant Flashing Lights with Multiple Tracks	\$3,451.00
III	2-Quadrant Flashing Lights and Gates with One Track	\$3,934.00
IV	2-Quadrant Flashing Lights and Gates with Multiple Tracks	\$4,940.00
V	3 or 4-Quadrant Flashing Lights and Gates with One Track	\$7,777.00
VI	3 or 4-Quadrant Flashing Lights and Gates with Multiple Tracks	\$9,759.00

AUTHORITY: FLORIDA ADMINISTRATIVE RULE 14-57.011
 Public Railroad-Highway Grade Crossing Costs

EFFECTIVE DATE: July 22, 1982

GENERAL AUTHORITY: 334.044, F.S.

SPECIFIC LAW IMPLEMENTED: 335.141, F.S.

*This schedule will become effective July 1, 2021 and will be reviewed every 5 years and revised as appropriate based on the Consumer Price Index for all Urban Consumers published by the U.S. Department of Labor.

PUBLIC HWY AT GRADE Commercial City: MIAMI IN CITY OPEN-TRACK ACTIVE

Rank 2022: 1790 SR No.: RR Company: SFRV Date:
 Rank 2021: 1814 CR No.: Division Name: SFRC Team Members:
 US No.: Subdivision Name: NA
 Latitude: 25.797900 Branch Name: DOWNTOWN SPUR
 Longitude: -80.220000 RR Milepost: 39.03

Field Review Comments:
 Team Recommendations:
 A S Preempt Cabinet Cable

Highway Speed: 30	<input type="checkbox"/>	Train Speed Range: 5-10	<input type="checkbox"/>
Crossing Angle: 60-90 DEG	<input type="checkbox"/>	Max Time Table Speed: 10	<input type="checkbox"/>
AA DT: 21500 (2020)	<input type="checkbox"/>	Day Thru/Switch: /	<input type="checkbox"/>
Percent Trucks: 10 (2020)	<input type="checkbox"/>	Night Thru/Switch: /	<input type="checkbox"/>
School Buses: 10 (2020)	<input type="checkbox"/>	Train Service: Freight	<input type="checkbox"/>
Street Types: Divided Highway	<input type="checkbox"/>	Passenger Count/Day: 0	<input type="checkbox"/>
Thru Lanes: 2	<input type="checkbox"/>	Train Count Date: 01/01/2014	<input type="checkbox"/>
Aux Lanes: 0	<input type="checkbox"/>	Main Tracks: 1	<input type="checkbox"/>
Hazmat Route? YES	<input type="checkbox"/>	Other Tracks: (1) Spur/Lead	<input type="checkbox"/>
Emergency Services Route? YES	<input type="checkbox"/>		<input type="checkbox"/>

Emergency Notification Signs: YES	<input type="checkbox"/>	Train Signals? NO	<input type="checkbox"/>
Crossbuck(4x4 post): 0	<input type="checkbox"/>	Train Signal Proximity: NO	<input type="checkbox"/>
Crossbuck Sign: 4	<input type="checkbox"/>	Train Detection: Constant Warning Time	<input type="checkbox"/>
Stop Sign: 0	<input type="checkbox"/>	Event Recorder?	<input type="checkbox"/>

Yield Sign: 0	<input type="checkbox"/>	Number of Bells: 2	<input type="checkbox"/>
Low Ground Clearance Signs: 0	<input type="checkbox"/>	Post Mounted Flashing Lights: 2	<input type="checkbox"/>
Exempt Signs:	<input type="checkbox"/>	Backlights, Incandescent	<input type="checkbox"/>
Trespass Signs: YES	<input type="checkbox"/>	Roadway Gate Count: 2	<input type="checkbox"/>

W10-1 <input type="checkbox"/> 0 EB WB NB SB	R10-6a <input type="checkbox"/> 0	W8-1 <input type="checkbox"/> 0	Gates: 2 Quad	<input type="checkbox"/>
W10-2 <input type="checkbox"/> 0	R11-2 <input type="checkbox"/> 0	W10-8 <input type="checkbox"/> 0	Cantilevered Flashing Over Traffic: 2	<input type="checkbox"/>
W10-3 <input type="checkbox"/> 0	R15-2P <input type="checkbox"/> 0	W10-9 <input type="checkbox"/> 0	Incandescent	<input type="checkbox"/>
W10-4 <input type="checkbox"/> 0	R15-6 <input type="checkbox"/> 0	W10-9P <input type="checkbox"/> 0	Cantilevered Flashing Not Over Traffic: 0	<input type="checkbox"/>
W10-11 <input type="checkbox"/> 0	R15-6a <input type="checkbox"/> 0	W10-11a <input type="checkbox"/> 0	Intersecting Roadway? YES	<input type="checkbox"/>
W10-12 <input type="checkbox"/> 0	R15-7 <input type="checkbox"/> 0	W10-11b <input type="checkbox"/> 0	Signalized? YES	<input type="checkbox"/>
R3-1a <input type="checkbox"/> 0	R15-7a <input type="checkbox"/> 0	W10-13P <input type="checkbox"/> 0	Interconnection: Not Interconnected	<input type="checkbox"/>
R3-2a <input type="checkbox"/> 0	R15-8 <input type="checkbox"/> 0	W10-14P <input type="checkbox"/> 0	Traffic Signals Controlling?	<input type="checkbox"/>
R8-8 <input type="checkbox"/> 2 Pvt Crossing	<input type="checkbox"/> 0	W10-14aP <input type="checkbox"/> 0	Preemption:	<input type="checkbox"/>
R8-9 <input type="checkbox"/> 0 Look Out	<input type="checkbox"/> 0	W10-15P <input type="checkbox"/> 0	Does traffic queue across the tracks? YES	<input type="checkbox"/>
R8-10 <input type="checkbox"/> 0 R8-8 w/Beacon	<input type="checkbox"/> 0	Slow <input type="checkbox"/> 0	Traffic Pre-Signals? NO	<input type="checkbox"/>
R8-10a <input type="checkbox"/> 0	W3-1 <input type="checkbox"/>	W10-1w/Beacon <input type="checkbox"/> 0	8" Count: 0	<input type="checkbox"/>
R10-6 <input type="checkbox"/> 0	W3-3 <input type="checkbox"/>	LED Signs <input type="checkbox"/> 0	12" Count: 10	<input type="checkbox"/>

Surface Installment Date:	<input type="checkbox"/>	Install - Upgrade: --	<input type="checkbox"/>
Surface Type: CONCRETE	<input type="checkbox"/>	Maintenance Responsibility: STATE	<input type="checkbox"/>
Pvmt Mrk:	<input type="checkbox"/>	Roadway Paved: YES	<input type="checkbox"/>

Redo Mrk: EB WB NB SB Trim Trees: EB WB NB SB		Tracks run down street? NO	<input type="checkbox"/>
Approach: A = Smooth	<input type="checkbox"/>	Sidewalks on Crossing Approach? YES	<input type="checkbox"/>
Vehicle Reaction: A = No reaction	<input type="checkbox"/>	Sidewalks Thru Crossing? YES	<input type="checkbox"/>
Driver Reaction: A = No reaction	<input type="checkbox"/>	Crossing illuminated? YES	<input type="checkbox"/>
Rail/Pad Movement: A = Smooth	<input type="checkbox"/>	Commerical Power? YES	<input type="checkbox"/>

Incident History:
 Recommended Warning Device: FL & G & P



DIAGNOSTIC FIELD REVIEW SUPPLEMENTAL FORM

Crossing Number/Mile Post: 628424V / SXD 39.03	Street/Road Name: NW 17th Avenue	Date: 3/30/2023
---	-------------------------------------	--------------------

OBSERVATIONS
<p>Obsolete Equipment</p>

RECOMMENDATIONS
<p>1: Railroad Recommendations: Replace all the equipment 6X6 House and all the equipment (CWT, etc) 2 new vehicle gate assemblies (Gates / LEDs / Bells) Batteries Service Pole Cables</p>
<p>2: Recommendations for Roadway Authority Refresh pavement markings</p>



Exhibit 1

Contract 21-032		
Railroad-Highway Road Crossing Construction and Traffic Control Device Installation Bid Sheet		
Item	Description	Cost
1.0	RAILROAD-HIGHWAY ROAD CROSSING - TRAFFIC CONTROL DEVICE INSTALLATION [2 of 7]	\$ 455,662.07
1.0	RAILROAD-HIGHWAY ROAD CROSSING - TRAFFIC CONTROL DEVICE INSTALLATION [3 of 7]	\$ 43,586.63
1.0	RAILROAD-HIGHWAY ROAD CROSSING - TRAFFIC CONTROL DEVICE INSTALLATION [4 of 7]	\$ 145,435.57
2.0	RAILROAD-HIGHWAY ROAD CROSSING - ROADWAY WORK	\$ 13,382.50
3.0	RAILROAD-HIGHWAY ROAD CROSSING - ADDITIONAL ITEMS	\$ 1,414.85
4.0	RAILROAD-HIGHWAY ROAD CROSSING - SIGNAL DESIGN & ENGINEERING	\$ -
	TOTAL	\$ 659,481.62

Item	Description	Units	No. of Units	Unit Cost (Material & Labor)	Total Cost
Contract 21-032					
1.1	Crossing Signal Assemblies				
1.1.1	Flasher Assembly, mast, 1-way, complete, with 12-inch LED Light Assemblies, and brackets (dimensions variable)	EA	2	5,724.72 \$	11,449.43
1.1.2	Flasher Assembly, mast, 2-way, complete, with 12-inch LED Light Assemblies, and brackets (dimensions variable)	EA	2	6,854.73 \$	-
1.1.3	Flasher Assembly, mast, 2-way, complete, with 12-inch LED Light Assemblies, and brackets (dimensions variable)	EA	2	38,740.20 \$	76,480.39
1.1.4	Entrance Gate Assembly, complete, S-60 Mechanism, installed	EA		18,240.20 \$	-
1.1.5	Exit Gate Assembly, complete, S-60 Mechanism, installed	EA		25,843.14 \$	-
1.1.6	Sidewalk Gate Kit, Entrance Gate, S-60 Gate Mechanism, arm brackets, rears, and all necessary mounting hardware, installed	EA		11,360.82 \$	-
1.1.7	Foundation for Flasher or Wayside Signal, Dine Precast DPS-1	EA	2	11,409.07 \$	23,004.15
1.1.8	Foundation for Gatearm or Wayside Signal, Dine Precast DPS-2				
1.2	Cantilevers and Signal Bridges				
1.2.1	Cantilever, 12 foot Single Mast including lights, signage, wiring and installed	EA		41,185.42 \$	-
1.2.2	Cantilever, 14 foot Single Mast including lights, signage, wiring and installed	EA		42,273.94 \$	-
1.2.3	Cantilever, 16 foot Single Mast including lights, signage, wiring and installed	EA		43,781.62 \$	-
1.2.4	Cantilever, 18 foot Single Mast including lights, signage, wiring and installed	EA		42,369.11 \$	-
1.2.5	Cantilever, 20 foot Single Mast including lights, signage, wiring and installed	EA		44,434.23 \$	-
1.2.6	Cantilever, 22 foot Single Mast including lights, signage, wiring and installed	EA		44,857.93 \$	-
1.2.7	Cantilever, 24 foot Single Mast including lights, signage, wiring and installed	EA		46,129.21 \$	-
1.2.8	Cantilever, 26 foot Single Mast including lights, signage, wiring and installed	EA		47,263.20 \$	-
1.2.9	Cantilever, 28 foot Single Mast including lights, signage, wiring and installed	EA		47,259.22 \$	-
1.2.10	Cantilever, 30 foot Single Mast including lights, signage, wiring and installed	EA		47,965.48 \$	-
1.2.11	Cantilever, 32 foot Double Mast including lights, signage, wiring and installed	EA		63,555.81 \$	-
1.2.12	Cantilever, 34 foot Double Mast including lights, signage, wiring and installed	EA		63,899.31 \$	-
1.2.13	Cantilever, 36 foot Double Mast including lights, signage, wiring and installed	EA		64,404.31 \$	-
1.2.14	Cantilever, 38 foot Double Mast including lights, signage, wiring and installed	EA		64,915.54 \$	-
1.2.15	Cantilever, 40 foot Double Mast including lights, signage, wiring and installed	EA		65,904.40 \$	-
1.2.16	Crossarm Assembly, for cantilever mast, 1-way, complete, with 12-inch LED Light Assemblies, bracket dimensions variable, installed	EA		5,124.84 \$	-
1.2.17	Crossarm Assembly, for cantilever mast, 2-way, complete, with 12-inch LED Light Assemblies, bracket dimensions variable, installed	EA		6,132.47 \$	-
1.2.18	Foundation for Cantilever, Dine Precast Single Mast DP-48	EA		18,809.21 \$	-
1.2.19	Foundation for Cantilever, Dine Precast Double Mast DP-88	EA		19,506.27 \$	-
1.2.20	Foundation for Cantilever, Dine Precast Double Mast DP-168	EA		25,080.51 \$	-
1.3	Crossing Signal Components (Included in Assemblies, Cantilevers and Signal Bridges)				
1.3.1	12-inch LED Light Assembly, pinelated, roof, complete-assembly with sheet aluminum hood and backround	EA		1,066.42 \$	-
1.3.2	Flasher Assembly, mast, 1-way, complete, with 12-inch LED Light Assemblies, and brackets (dimensions variable)	EA	4	5,532.67 \$	22,210.68
1.3.3	Flasher Assembly, mast, 2-way, complete, with 12-inch LED Light Assemblies, and brackets (dimensions variable)	EA	2	6,682.68 \$	13,365.36
1.3.4	Gate Arm Light Assembly, complete, set of 2 Red LED Lights, wiring, cable clips, and all necessary mounting hardware	EA		376.12 \$	-
1.3.5	Gate Mechanism: Entrance, Siemens S-60, 6-cam, w/o MTSS, complete assembly	EA		32,705.19 \$	-
1.3.6	Gate Mechanism: Exit, Siemens S-60, 6-cam, w/o MTSS, complete assembly	EA	2	1,289.00 \$	2,578.00
1.3.7	Bell, Electronic	EA		151.53 \$	-
1.3.8	Prismacle, cast aluminum with hardware	EA	2	284.31 \$	568.62
1.3.9	Crossing Sign for typical grade crossing	EA		4,416.43 \$	-
1.3.10	Mast	EA		5,331.74 \$	-
1.3.11	Base, Split, with junction box	EA		2,895.97 \$	-
1.3.12	Counterweight Arm Assembly, Left Hand or Right Hand, Cast-iron, with mounting plate and equipment	EA		349.04 \$	-
1.3.13	High Wind Gate Arm Support	EA			-
1.4	Signal Enclosure				
1.4.1	Signal Enclosure, 4'x4', PTMW, Aluminum, with AC/Heat, wired, tested and installed (ElectroLogix XP4)	EA		197,726.93 \$	-
1.4.2	Signal Enclosure, 6'x4', PTMW, Aluminum, with AC/Heat, wired, tested and installed (ElectroLogix XP4)	EA		268,479.18 \$	-
1.4.3	Signal Enclosure, 6'x6', PTMW, Aluminum, with AC/Heat, wired, tested and installed (ElectroLogix XP4)	EA	1	306,005.44 \$	306,005.44
1.4.4	Signal Enclosure, 8'x8', PTMW, Aluminum, with AC/Heat, wired, tested and installed (ElectroLogix XP4)	EA		376,070.35 \$	-

\$ 455,662.07

Contract 21-032

1.0 TRAFFIC CONTROL DEVICE INSTALLATION

Item	Description	Units	No. of Units	Unit Cost (Material & Labor)	Total Cost
1.4.5	Signal Enclosure, 10"x10" PTMW, Aluminum, with AC/Heat, wired, tested and installed [ElectroLogix XP4]	EA		543,667.98 \$	
1.4.6	Signal Cabinet, 60" wide, PTMW, Aluminum, with AC/Heat, wired, tested and installed [ElectroLogix XP4]	EA		191,996.37 \$	
1.4.7	Connection to Traffic Cabinet for Preemption	LS		2,403.23 \$	
1.4.8	DAX/UAX circuitry and programming, if needed. Add 10% of location cost 1.4.1 - 1.4.7	%			
1.5	Signal Enclosure Components (Items included in wired and installed signal enclosure)				
1.5.1	ElectroLogix XP4 Crossing Controller	EA		73,713.66 \$	
1.5.2	XP4 Crossing Interface Panel, XP-20B, 20A, P/N 227561-100	EA		1,746.65 \$	
1.5.3	Panel, Surge Arrester, MDSA-1X5 (1 Track), P/N 250204-100	EA		1,746.78 \$	
1.5.4	Panel, Surge Arrester, MDSA-2X5 (2 Track), P/N 250675-100	EA		2,240.13 \$	
1.5.5	Recorder, Event Analyzer, SEAR II	EA		16,195.38 \$	
1.5.6	12VDC Battery Charger	EA		1,384.16 \$	
1.5.7	24VDC Battery Charger	EA		1,687.85 \$	
1.5.8	DC Converter Module A53106	EA		2,775.49 \$	
1.5.9	Stepdown Transformer	EA		3,072.12 \$	
1.5.11	Terminals/Fuses/Arrestors/Wago Terminations/Cable Management Percentage of 1.4 item	%			
1.5.12	Case Wire, installed, tested, tagged and terminated Percentage of 1.4 item	%			
1.5.13	NAS Micro Data Analyzer II with Ritron DTMF Radio	EA		14,116.01 \$	
1.5.14	NAS DTMF Antenna Kit (to be procured and installed with item 1.5.13)	EA			
1.5.15	SINAS Bulk Head Polyphaser (to be procured and installed with item 1.5.13)	EA	1	7,168.00 \$	7,168.00
1.5.16	Electrical Meter Service Pole, wood, Class B, 25' long, complete assembly, 25 per SFRTA SS351	EA	1	397.80 \$	397.80
1.5.17	WAGO Track and Signal Surge Protection	EA	1	15,382.30 \$	15,382.30
1.5.18	WAGO Signals Health Monitoring System	EA		3,432.21 \$	
1.5.19	WAGO Signals Health Monitoring System - NAS DTMF controller and antenna	EA	1	27.77 \$	27.77
1.5.20	ETHERNET cable, Cat. 6A, RJ-45; Length: 3 m (9.8 ft); Green	EA		52.96 \$	
1.5.21	WAGO ETHERNET cable, Cat. 6A, RJ-45; Length: 7.5 m (24.6 ft); Green	EA		72.32 \$	
1.5.22	WAGO ETHERNET cable, Cat. 6A, RJ-45; Length: 10 m (32.8 ft); Green	EA		96.10 \$	
1.5.23	WAGO Battery Bus - negative (-)	EA	3	560.81 \$	1,682.43
1.5.24	WAGO Battery Bus - positive (+)	EA	3	580.79 \$	1,742.38
1.5.25	WAGO Charge-Battery-Load Unit	EA		835.54 \$	
1.5.26	WAGO Gate Mech Base Junction Box	EA		539.44 \$	
1.5.27	WAGO Gate Mech Mast Junction Box	EA		537.39 \$	
1.5.28	WAGO Positive Light Circuit (LNX)	EA		539.03 \$	
1.5.29	WAGO Track circuit arrester with Equalizer Circuit	EA	2	475.24 \$	950.47
1.5.31	WAGO Signal line arrester	EA	12	451.37 \$	5,416.44
1.5.32	WAGO TOPJOB'S lumbar, for 2002 series; insulated; 2-way; light; gray	EA		2.66 \$	
1.5.33	WAGO TOPJOB'S feedthrough terminal block; angled profile; rail mount; 3-conductor; 5.2 mm wide; orange	EA		10.40 \$	
1.5.34	WAGO TOPJOB'S feedthrough terminal block; angled profile; rail mount; 3-conductor; 5.2 mm wide; blue	EA		10.40 \$	
1.5.35	WAGO TOPJOB'S end/intermediate plate; for 2002-680x and 2002-600x series terminal blocks; 0.8 mm wide;	EA		1.81 \$	
1.5.36	WAGO TOPJOB'S feedthrough terminal block; rail mount; 2-conductor; 7.5 mm wide; gray	EA	25	11.68 \$	292.00
1.5.37	WAGO TOPJOB'S feedthrough terminal block; rail mount; 2-conductor; 7.5 mm wide; orange	EA	25	3.60 \$	90.00
1.5.38	WAGO End and intermediate plate; 1 mm thick orange	EA	25	3.35 \$	83.69
1.5.39	WAGO Disconnect terminal block; rail mount; with test option; 2-conductor; 7.5 mm; blue	EA	25	3.33 \$	83.25
1.5.40	WAGO Disconnect terminal block; with test option; orange; disconnect ling.; 2-conductor; 7.5 mm; blue	EA		11.68 \$	
1.5.41	WAGO Lockout cap. for wire insertion and actuating opening	EA		0.81 \$	
1.5.42	WAGO Push-in type jumper bar; insulated; 2-way; Nominal current 41 A	EA		1.05 \$	
1.5.43	WAGO Push-in type jumper bar; insulated; 5-way; Nominal current	EA		4.04 \$	
1.5.44	WAGO Marking strips; for Smart Printer; on reel; not stretchable; plain; Snap-On type; white	EA		368.24 \$	
1.5.45	WAGO TOPJOB'S finger guard, touchproof cover protects unused conductor entry slots; for 2010 series	EA		0.68 \$	

\$ 43,586.63

Contract 21-032

Item	Description	Units	No. of Units	Unit Cost (Material & Labor)	Total Cost
1.5.47	WAGO TOPJOB-S ground terminal block; rail mount; 2-conductor; 10 mm wide; green-yellow	EA		9.75 \$	
1.5.48	WAGO Step-down jumper; insulated; light gray	EA		2.92 \$	
1.5.49	WAGO Steel carrier rail; 35 x 7.5 mm; 1 mm thick; 2 m long; slotted; according to EN 60715; "Hole width 18 mm;	EA		16.89 \$	
1.5.50	WAGO Copper carrier rail; 35 x 15 mm; 2.3 mm thick; 2 m long; unslotted; according to EN 60715; copper-colored	EA		382.24 \$	
1.5.51	WAGO TOPJOB-S feedthrough terminal block with Lever and Open Tool Slot; rail mount; 2-conductor; 10 mm wide;	EA		13.81 \$	
1.5.52	WAGO TOPJOB-S feedthrough terminal block with Lever and Open Tool Slot; rail mount; 2-conductor; 10 mm wide;	EA		7.16 \$	
1.5.53	WAGO End and intermediate plate; 1 mm thick; orange	EA		1.07 \$	
1.5.54	WAGO TOPJOB-S feedthrough terminal block with Lever and Open Tool Slot; rail mount; 3-conductor; 10 mm wide;	EA		11.40 \$	
1.5.55	WAGO End and intermediate plate; 1 mm thick; for 3-conductor terminal blocks; orange	EA		2.19 \$	
1.5.56	WAGO Screwless end stop; 6 mm wide; for DIN rail 35 x 15 and 35 x 7.5; gray	EA		1.36 \$	
1.5.57	WAGO Power supply; Pro 2; 1-phase; 24 VDC output voltage; 20 A output current; TopBoost + PowerBoost;	EA		564.86 \$	
1.5.58	WAGO 16-channel digital input; 24 VDC; 3 ms; Extreme; dark gray	EA		320.92 \$	
1.5.59	WAGO 8-channel digital output; 24 VDC; 0.5 A; 2-conductor connection; Extreme	EA		274.03 \$	
1.5.60	WAGO 2-channel analog input; 0 ... 30 VDC; Differential input; Extreme; dark gray	EA		442.68 \$	
1.5.61	WAGO End Module; Extreme; dark gray	EA		50.13 \$	
1.5.62	WAGO Controller; PFC200; 2nd Generation; 4 x ETHERNET; Extreme	EA		1,858.87 \$	
1.5.63	WAGO Touch Panel 600 Standard Line; 10.1" (25.7 cm); 1280 x 800 pixels; 2 x USB; 2 x ETHERNET; Web Panel	EA	1	2,406.92 \$	2,406.92
1.5.64	WAGO Lead acid AGM battery module; 24 VDC; 3.2 Ah	EA		308.92 \$	
1.5.65	WAGO UPS charger and controller; 24 VDC; 20 A	EA		521.50 \$	
1.6	Field Material				
1.6.1	Battery Bank for Gates and Lights, Furnished and Installed	LS	2	3,774.56 \$	7,549.11
1.6.2	Battery Bank for Electronics, Furnished and Installed	LS	1	3,291.48 \$	3,291.48
1.6.3	Furnish and Install Termination Shunts	LS	2	2,013.15 \$	4,026.30
1.7	Signal Cable				
1.7.1	Cable 2C #6 TW	FT	225	41.28 \$	9,288.80
1.7.2	Cable 4C #2 (Power Drop)	FT	50	25.59 \$	1,279.28
1.7.3	Cable 7C #14	FT		40.30 \$	
1.7.4	Cable 7C #6	FT	500	58.23 \$	29,116.86
1.7.5	Cable 9C #14	FT		44.11 \$	
1.7.6	Cable 4C #18	FT		4.41 \$	
1.7.7	Cable 12C #14	FT		44.11 \$	
1.7.8	Pull All Cables	FT	775	72.39 \$	56,101.38
1.7.9	Terminate and Test All Cables	EA	7	114.23 \$	799.60
1.8	Miscellaneous				
1.8.1	Demolition existing structures (if applicable) - Percentage of Total Project Cost	%	2%	631,516.77 \$	12,630.34
1.8.2	Proper disposal of construction debris (includes debris generated from 1.8.1) - Percent of Total Project Cost	%	3%	631,516.77 \$	18,945.50
				\$	145,435.57

Contract 21-032
2.0 ROADWAY WORK

Item	Description	Units	No. of Units	Unit Cost (Material and Labor)	Total Cost
2.1	Superpave Asphaltic Concrete, Traffic C	TN		900.00 \$	-
2.2	Asphaltic Concrete Friction Course (FC-9.5)	TN		1,000.00 \$	-
2.3	Milling Existing Asphalt Pavement, 1-1/2" Avg depth	SY		25.00 \$	-
2.4	MAINTENANCE OF TRAFFIC	DY	2	4,160.00 \$	8,320.00
2.5	Variable Message Board, for MOT per day ¹	EA		\$	-
2.6	CONCRETE CURB & GUTTER, TYPE F	LF		62.50 \$	-
2.7	CONCRETE SIDEWALK AND DRIVEWAYS, 4" THICK	SY	10.00	500.00 \$	5,000.00
2.8	ADA-COMPLIANT CAST-IN-PLACE DETECTABLE WARNING	SF	1	62.50 \$	62.50
2.9	SINGLE POST SIGN	AS		2,000.00 \$	-
2.10	THERMOPLASTIC, STANDARD, WHITE, SOLID, 24" FOR STOP LINE AND CROSSWALK	LF		20.00 \$	-
2.11	THERMOPLASTIC, STANDARD, WHITE, MESSAGE OR SYMBOL	EA		530.00 \$	-
2.12	THERMOPLASTIC, STANDARD-OTHER SURFACES, WHITE, SOLID, 6"	GM		23,000.00 \$	-
2.13	THERMOPLASTIC, OTHER SURFACES, WHITE, SKIP, 6", 10-30 SKIP OR 3-9 LANE DROP	GM		23,000.00 \$	-
2.14	THERMOPLASTIC, STANDARD-OTHER SURFACES, YELLOW, SOLID, 6"	GM		23,000.00 \$	-
2.15	Reflective Pavement Marker	EA		15.00 \$	-
2.16	Sod - Landscaping	SYD		66.37 \$	-
2.17	Dura-Post Delineator, High Performance Flexible Delineator, 36" Orange Post, Two 3" wide silver high intensity flexible prismatic reflective bands, (FDOT APL 705-000-009)	EA		175.00 \$	-
2.18	Survey, includes signed and sealed drawings	EA		11,000.00 \$	-

Total for 2.0 Roadway Work

13,382.50

¹ Total Cost for this line shall be calculated as number of units per number of days required.

TOP ROW

12 FB	08	12 B	12 F	12 FB	12 FB	12 FB	12 FB
15 FB	09	15 B	15 F	15 FB	15 FB	15 FB	15 FB
22	33B	22 B	22 F	22 FB	22 FB	22 FB	22 FB
25	33B	25 B	25 F	25 FB	25 FB	25 FB	25 FB
32	33B	32 B	32 F	32 FB	32 FB	32 FB	32 FB
35	33B	35 B	35 F	35 FB	35 FB	35 FB	35 FB

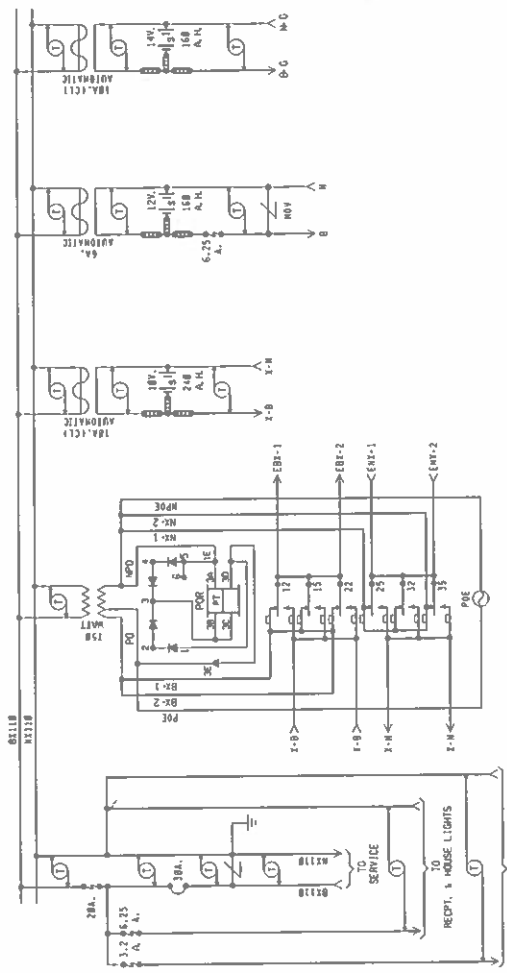

- NOTES:
- 1 - REFERENCES ARE PER SCMS-13.
 - 2 - ARRESTERS ARE PER SCMS-22.
 - 3 - GROUND CONNECTIONS ARE PER SCMS-18.
 - 4 - SHELF RELAY PLACEMENT ON CONSIST CHART HAS NO SIGNIFICANCE.
 - 5 - PLUG-IN RELAYS ARE VIEWED FROM THE FRONT OF RACK.
 - 6 - ALL WIRING IS TO BE VIEWED FROM THE FRONT OF RACK.
 - 7 - WIRING
 - A - FEED TO ALL BUSES. LIGHT CIRCUITS, MOTOR CIRCUITS AND 110-VOLT FEED FROM ENTRANCE TO POWER BUS, TO BE #10 FEET.
 - B - FROM POWER BUSES TO RECTIFIER AND TRANSFORMER TO BE #14 FEET.
 - C - ALL OTHERS TO BE #16 FEET UNLESS NOTED.

4' X 6' RELAY HOUSE

RAIL TRANSPORT GROUP ENGINEERING COMMUNICATIONS AND SIGNALS		DESIGNED	DIGITIZED	CHECKED	DATE
04-19-91 HAR	FL2881055	3003193	3003193	3003193	95-11-98
31-14-01 IRS FL2881123	FL2881055	NEXT SH	NEXT SH	NEXT SH	FILE
02-17-96 SHE	FL2881046	3003193	3003193	3003193	3003193
07-17-99 SAF	FL2881046	3003193	3003193	3003193	3003193
08-04-13 IRL	FL2881046	3003193	3003193	3003193	3003193
NW 17TH AVE. 628424V CORPORATE SHOP EDUCATION BLDG MIAMI, FL 33130-39-01					

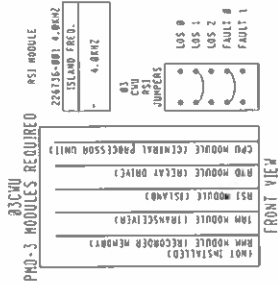

FRONT VIEW

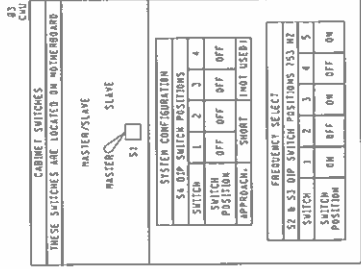
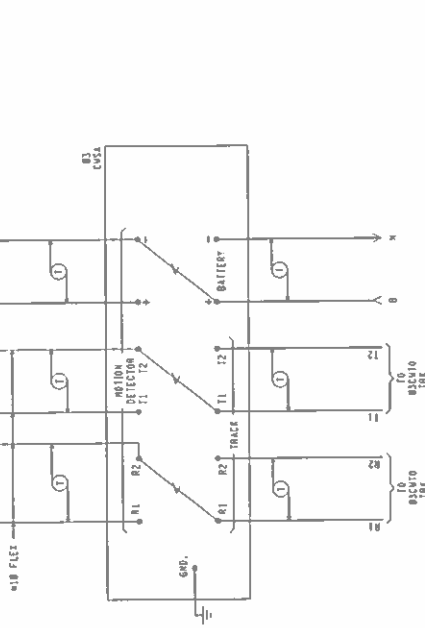

REVISONS	
86-84-113 REL	FELBLERZ
RAIL TRANSPORT GROUP ENGINEERING COMMUNICATIONS AND SIGNALS	
NW 11TH AVE. 628424V DOWNTOWN SPUR CRASSIE DETECTION CIRCUITRY MIAMI, FL. M.P. 510-35.83	
DRAWING SHEET NO.
NEXT SH
DESIGNED REL	51003983
DIGITIZED REL
CHECKED REL
DATE	86-84-113
FILE	51003983
SHEET	001

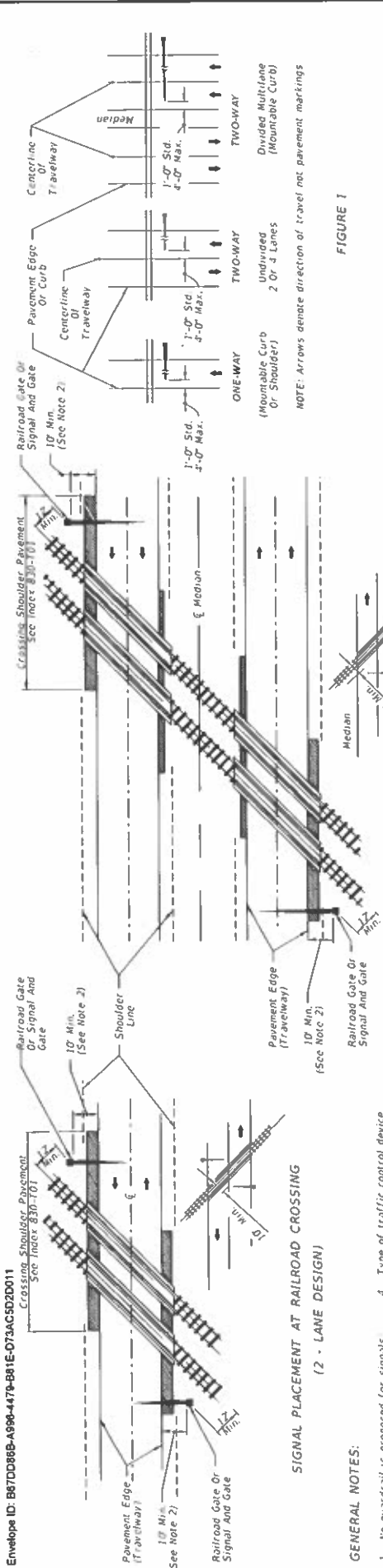

FIGURE 1
SIGNAL PLACEMENT AT RAILROAD CROSSING
(2 - LANE CROSSING)
(4 - LANE DESIGN)

GENERAL NOTES:

- 1 No guardrail is proposed for signals, however, some form of impact protection may be specified for certain locations.
- 2 Advance flasher to be installed when and if called for in Plans or Specifications.
- 3 Top of foundation shall be no higher than 4" above finished shoulder grade.
- 4 Type of traffic control device
 - I Flashing warning devices with cant-lever
 - II Flashing warning devices with gate
 - III Flashing warning devices with cant-lever and gate
 - IV Flashing warning devices with cant-lever and gate
- 5 Class of traffic control devices (Not Shown)
 - I 2 Quadrant flashing warning devices-one track
 - II 2 Quadrant flashing warning devices-multiple tracks
 - III 2 Quadrant flashing warning devices and gates-one track
 - IV 2 Quadrant flashing warning devices and gates-multiple tracks
 - V 2 Quadrant flashing warning devices and gates-one track
 - VI 2-4 Quadrant flashing warning devices and gates-multiple tracks

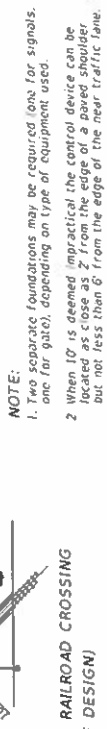

FIGURE 2
SIGNAL PLACEMENT AT RAILROAD CROSSING
(ONE-WAY)
(TWO-WAY)

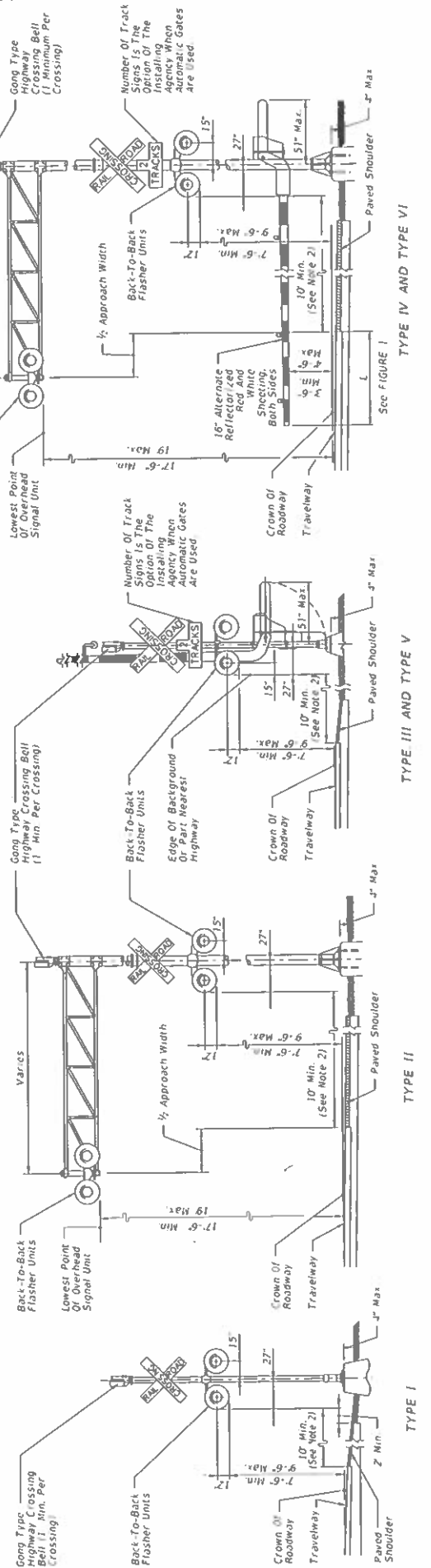

FIGURE 3
TRAFFIC CONTROL DEVICES FOR FLUSH SHOULDER ROADWAY
TYPE I
TYPE II
TYPE III AND TYPE V

LAST REVISION	02/05/21
DESCRIPTION:	

FOOT
STANDARD PLANS
FY 2023-24

RAILROAD GRADE CROSSING
TRAFFIC CONTROL DEVICES

INDEX
509-070
SHEET
1 of 3

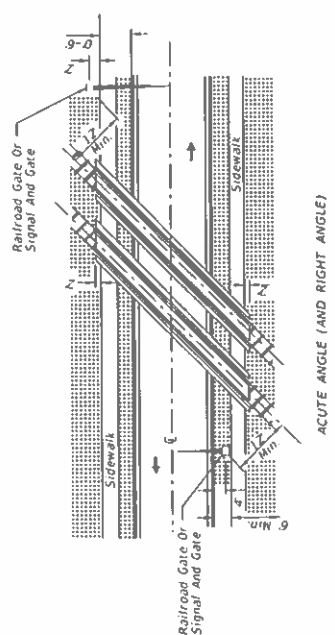

ACUTE ANGLE (AND RIGHT ANGLE)
SIGNAL PLACEMENT AT RAILROAD CROSSING
(2 LANES, CURB & GUTTER)

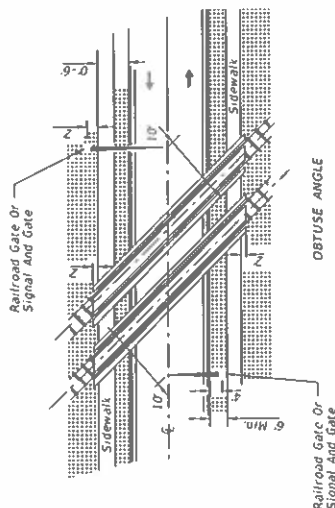

OBTUSE ANGLE
SIGNAL PLACEMENT AT RAILROAD CROSSING
(2 LANES, CURB & GUTTER)

- NOTES:**
1. The location of flashing warning devices and stop lines shall be established based on future (or present) installation of gate with appropriate track clearances.
 2. Where plans call for railroad traffic control devices to be installed in curbed medians, the minimum median width shall be 12'-6"
 3. Location of railroad traffic control device is based on the distance available between face of curb & sidewalk to 6'. Locate device outside sidewalk. Over 6' - Locate device between face of curb and sidewalk.
 4. Stop line to be perpendicular to edge of roadway, approx. 15' from nearest rail, or 8' from and parallel to gate when present.
 5. When a cantilevered-arm flashing warning device is used, the minimum vertical clearance shall be 17'-6" from above the Crown of Roadway to the Lowest Point of the Overhead Signal Unit.

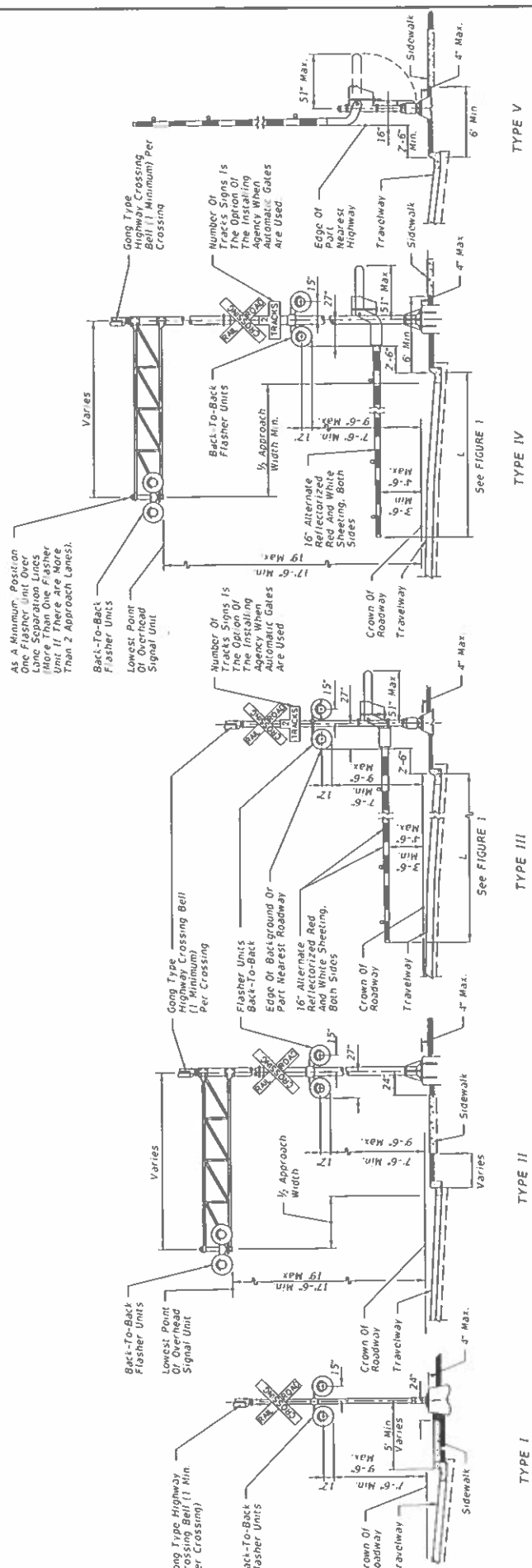

LAST REVISION	DESCRIPTION	INDEX	SHEET
02/05/21		509-070	2 of 3

RAILROAD GRADE CROSSING
TRAFFIC CONTROL DEVICES

FY 2023-24
STANDARD PLANS



TRAFFIC CONTROL DEVICES FOR CURBED ROADWAY

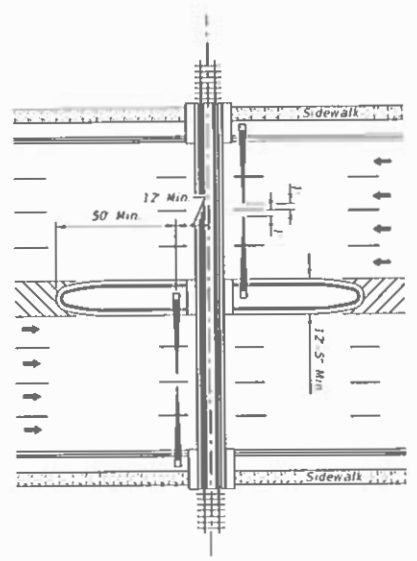

PLAN

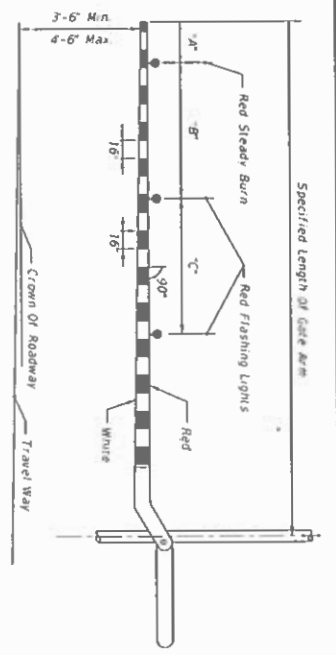

GATE ARM DETAIL

Specified Length Of Gate Arm	Dimension "A"	Dimension "B"	Dimension "C"
14 Ft.	6"	36"	5'
15 Ft.	18"	36"	5'
16-17 Ft.	24"	36"	5'
18-19 Ft.	28"	41"	5'
20-23 Ft.	28"	41"	5'
24-28 Ft.	28"	5'	5'
29-31 Ft.	36"	6'	6'
32-34 Ft.	36"	7'	7'
35-37 Ft.	36"	9'	9'
38 and Over	36"	10'	10'

NOTE:

For additional information see the "Manual On Uniform Traffic Control Devices", Part 8: The Traffic Control Handbook, Part VIII: and AASHTO "A Policy On Geometric Design Of Streets And Highways"

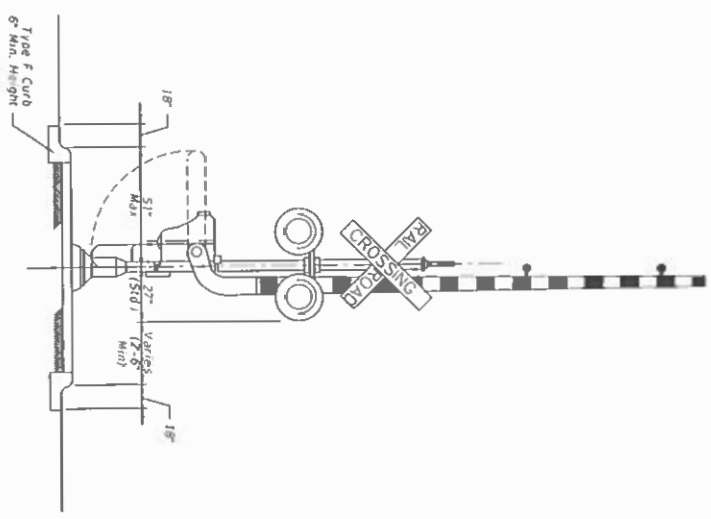

MEDIAN SECTION AT SIGNAL GATES

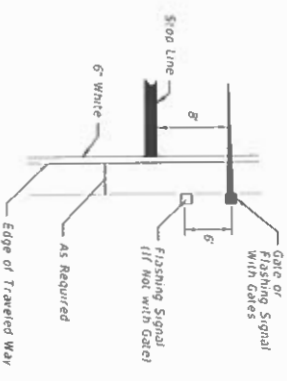

RELATIVE LOCATION OF CROSSING TRAFFIC CONTROL DEVICES

MEDIAN SIGNAL GATES FOR MULTILANE UNDIVIDED URBAN SECTIONS (Three or More Driving Lanes in one Direction, 45 mph or less)

LAST REVISION 02/05/21	DESCRIPTION	FDOT STANDARD PLANS	FY 2023-24	RAILROAD GRADE CROSSING TRAFFIC CONTROL DEVICES	INDEX 509-070	SHEET 3 OF 3
---------------------------	-------------	------------------------	------------	---	------------------	-----------------