



# FINAL AGENDA

**Community Zoning Appeals Board 7**  
Dr. Martin Luther King, Jr. Center, Conference Rooms 1-4, 2525 NW 62 Street, Miami, FL  
Thursday, March 5, 2026 at 7:00 pm

PREVIOUSLY DEFERRED

APPEALS

CURRENT

- |    |             |                                   |        |          |   |
|----|-------------|-----------------------------------|--------|----------|---|
| 1. | Z2024000192 | Biscayne Real Estate Holdings LLC | 24-192 | 52-42-29 | N |
|----|-------------|-----------------------------------|--------|----------|---|



# Official Zoning Agenda

COMMUNITY ZONING APPEALS BOARD

## COMMUNITY ZONING APPEALS BOARD - AREA 7

MEETING OF MARCH 5, 2026

DR. MARTIN LUTHER KING, JR., CENTER, CONFERENCE ROOMS 1 - 4

2525 NW 62 STREET, MIAMI, FLORIDA.

NOTICE: THE FOLLOWING HEARINGS ARE SCHEDULED FOR 7:00 P.M., AND

ALL PARTIES SHOULD BE PRESENT AT THAT TIME

ANY PERSON MAKING IMPERTINENT OR SLANDEROUS REMARKS OR WHO BECOMES BOISTEROUS WHILE ADDRESSING THE COMMUNITY ZONING APPEALS BOARD SHALL BE BARRED FROM FURTHER AUDIENCE BEFORE THE COMMUNITY ZONING APPEALS BOARD BY THE PRESIDING OFFICER, UNLESS PERMISSION TO CONTINUE OR AGAIN ADDRESS THE BOARD BE GRANTED BY THE MAJORITY VOTE OF THE BOARD MEMBERS PRESENT.

NO CLAPPING, APPLAUDING, HECKLING OR VERBAL OUTBURSTS IN SUPPORT OR OPPOSITION TO A SPEAKER OR HIS OR HER REMARKS SHALL BE PERMITTED. NO SIGNS OR PLACARDS SHALL BE ALLOWED IN THE MEETING ROOM. PERSONS EXITING THE MEETING ROOM SHALL DO SO QUIETLY.

THE USE OF CELL PHONES IN THE MEETING ROOM IS NOT PERMITTED. RINGERS MUST BE SET TO SILENT MODE TO AVOID DISRUPTION OF PROCEEDINGS. INDIVIDUALS, INCLUDING THOSE ON THE DAIS, MUST EXIT THE MEETING ROOM TO ANSWER INCOMING CELL PHONE CALLS. COUNTY EMPLOYEES MAY NOT USE CELL PHONE CAMERAS OR TAKE DIGITAL PICTURES FROM THEIR POSITIONS ON THE DAIS.

THE NUMBER OF FILED PROTESTS AND WAIVERS ON EACH APPLICATION WILL BE READ INTO THE RECORD AT THE TIME OF HEARING AS EACH APPLICATION IS READ.

THOSE ITEMS NOT HEARD PRIOR TO THE ENDING TIME FOR THIS MEETING, WILL BE DEFERRED TO THE NEXT AVAILABLE ZONING HEARING MEETING DATE FOR THIS BOARD.

## **SWEARING IN OF WITNESSES**

### **SELECTION OF CHAIR AND VICE CHAIR**

---

#### **1. BISCAYNE REAL ESTATE HOLDINGS, LLC. Z2024000192**

**Area 08/District 04**

The application is to permit a portion of the exiting building to be use as a new and used automobile dealership and the modification of a condition of prior resolutions in order to submit new site plans. In addition, the application seeks ancillary non-use variances to allow more lot coverage and more Floor Area Ratio (FAR) than permitted by Code, a reduction in the number of required off-street parking spaces, and a greenbelt that is narrower than the minimum required by code.

- (1) SPECIAL EXCEPTION to permit a new and used automobile dealership.
- (2) MODIFICATION of Condition #2 of Resolution No. 4-ZAB-317-82, passed and adopted by the Metropolitan Dade County Zoning Appeals Board, last modified by Resolution No. 4-ZAB-10-92, passed and adopted by the Metropolitan Dade County Zoning Appeals Board, and reading as follows:

FROM: "2. That in the approval of the plan, the same be substantially in accordance with that submitted for the hearing as prepared by James Beadman and Assoc., Inc., dated May 16, 1991, consisting of one page; plans entitled, "Contract Document Paradiso Caffè", as prepared by H.M. Grossman & Associates, consisting of 2 pages, dated stamped received January 13, 1992; site plans prepared by Morris Aubrey, Architects, dated received August 28, 1991, consisting of one page; "Biscayne Parking Analysis", as prepared by Bernal and Vazquez dated revised 1/9/92, consisting of one sheet; floor plan of first floor indicating location of nightclub dated received August 28, 1991."

TO: "2. That in the approval of the plan, the same be substantially in accordance with that submitted for the hearing entitled "Biscayne Center Improvements" consisting of 2 sheets (C-1 and EX-1), prepared by Thomas Engineering Group, dated stamped received 10/24/2025, 3 sheets (A101, A102 and A201) entitled "Biscayne Automotive", prepared by SPARC+ Architecture Studio, dated stamped received 4/1/2025 and 4 sheets (TD-1, TD-2, LA-1, and LA-2) entitled "Biscayne Center", prepared by Dixie Landscape, dated stamped received 10/24/2025, for a total of 9 sheets. Except as may be specified by any zoning resolution applicable to the subject property, any future modifications on the property which conform to zoning code requirements will not require further public hearing action.

The purpose of request #1 is to modify conditions to allow the submittal of a new site plan for the property to redevelop a portion of the Property with a new and used automobile dealership.

- (3) NON-USE VARIANCE to permit a lot coverage of 48.3% (40% maximum permitted).
- (4) NON-USE VARIANCE to permit a Floor Area Ratio of 1.36 (1.17 maximum permitted).
- (5) NON-USE VARIANCE to permit 461 parking spaces (516 parking spaces required).
- (6) NON-USE VARIANCE to permit a greenbelt varying from 10.88' to 52.43' in width along the front property line abutting a right-of-way (minimum 15' wide greenbelt along the front property line abutting a right-of-way required).

The aforementioned plans are on file and may be examined in the Department of Regulatory and Economic Resources. Plans may be modified at public hearing.

**LOCATION:** 11900 Biscayne Boulevard, Miami-Dade County, Florida.

**SIZE OF PROPERTY:** ±2.74 Acres

Department of Regulatory and  
Economic Resources  
Recommendation:

**Approval With Conditions.**

Protests: \_\_\_\_\_ 0 \_\_\_\_\_

Waivers: \_\_\_\_\_ 0 \_\_\_\_\_

APPROVED: \_\_\_\_\_

DENIED WITH PREJUDICE: \_\_\_\_\_

DENIED WITHOUT PREJUDICE: \_\_\_\_\_

DEFERRED \_\_\_\_\_

**NOTICE**

\*\*\*\*\*

THE FOLLOWING SUMMARY INFORMATION IS PROVIDED AS A COURTESY; IT SHOULD NOT BE TREATED AS LEGAL ADVICE AND IT SHOULD NOT BE RELIED UPON. LEGAL CONSULTATION MAY BE WARRANTED IF AN APPEAL OR OTHER LEGAL CHALLENGE IS BEING CONTEMPLATED.

\*\*\*\*\*

Decisions of the Community Zoning Appeals Board (CZAB) may be subject to appeal or other challenge. For example, depending upon the nature of the requests and applications addressed by the CZAB, a CZAB decision may be directly appealable to the Board of County Commissioners (BCC) or may be subject to challenge in Circuit Court. Challenges asserted in Circuit Court, where available, must ordinarily be filed within 30 days of the transmittal of the pertinent CZAB resolution to the Clerk of the BCC. Appeals to the BCC, where available, must be filed with the Zoning Hearing Section of the [Department of Regulatory and Economic Resources \(RER\)](#), or its successor Department, within 14 days after RER has posted a short, concise statement (such as that furnished above for the listed items) that sets forth the action that was taken by the CZAB. (RER's posting will be made on a bulletin board located in the office of RER.) All other applicable requirements imposed by rule, ordinance, or other law must also be observed when filing or otherwise pursuing any challenge to a CZAB decision.

Further information regarding options and methods for challenging a CZAB decision may be obtained from sources that include, but are not limited to, the following: Sections 33-312, 33-313, 33-314, 33-316, and 33-317 of the Code of Metropolitan Dade County, Florida; the Florida Rules of Appellate Procedure; and the Municode website ([www.municode.com](http://www.municode.com)). Miami-Dade County does not provide legal advice regarding potential avenues and methods for appealing or otherwise challenging CZAB decisions; however, a licensed attorney may be able to provide assistance and legal advice regarding any potential challenge or appeal.

**Miami-Dade County Department of Regulatory and Economic Resources  
Staff Report to Community Council No. 7**

**PH: Z24-192**

**March 5, 2026**

**Item No. 1**

<b>Recommendation Summary</b>	
<b>Commission District</b>	4
<b>Applicant</b>	Biscayne Real Estate Holdings, LLC.
<b>Summary of Requests</b>	The applicant seeks to permit a portion of an existing building to be used as a new and used automobile dealership and seeks the modification of a condition of prior resolution in order to submit new site plans. Additionally, the applicant seeks ancillary non-use variances to allow more lot coverage and more Floor Area Ratio (FAR), a reduction in the number of required off-street parking spaces, and for a greenbelt width that is narrower than the minimum required by Code.
<b>Location</b>	11900 Biscayne Boulevard, Miami-Dade County, Florida.
<b>Property Size</b>	±2.74 Acres
<b>Existing Zoning</b>	BU-2, Special Business District
<b>Existing Land Use</b>	Office building
<b>2023-2040 CDMP Land Use Designation</b>	Business and Office and within <i>one-half mile of a Rapid Transit Activity Corridor</i> (see attached Zoning Recommendation Addendum)
<b>Comprehensive Plan Consistency</b>	Consistent with interpretative text, goals, objectives and policies of the CDMP
<b>Applicable Zoning Code Section(s)</b>	Section 33-311(A)(3), Special Exception, Unusual use and New Uses, Section 33-311(A)(4)(b) Non-Use Variances from other than airport regulations Section 33-311(A)(7) Generalized Modification Standards, (see attached Zoning Recommendation Addendum)
<b>Recommendation</b>	<b>Approval with conditions.</b>

**REQUESTS:**

- (1) SPECIAL EXCEPTION to permit a new and used automobile dealership.
- (2) MODIFICATION of Condition #2 of Resolution No. 4-ZAB-317-82, passed and adopted by the Metropolitan Dade County Zoning Appeals Board, last modified by Resolution No. 4-ZAB-10-92, passed and adopted by the Metropolitan Dade County Zoning Appeals Board, and reading as follows:

FROM: "2. That in the approval of the plan, the same be substantially in accordance with that submitted for the hearing as prepared by James Beadman and Assoc., Inc., dated May 16, 1991, consisting of one page; plans entitled, "Contract Document Paradiso Caffè", as prepared by H.M. Grossman & Associates, consisting of 2 pages, dated stamped received January 13, 1992; site plans prepared by Morris Aubrey, Architects, dated received August 28, 1991, consisting of one page; "Biscayne Parking Analysis", as prepared by Bernal and Vazquez dated revised 1/9/92, consisting of one sheet; floor plan of first floor indicating location of nightclub dated received August 28, 1991."

TO: "2. That in the approval of the plan, the same be substantially in accordance with that submitted for the hearing entitled "Biscayne Center Improvements" consisting of 2 sheets (C-1 and EX-1), prepared by Thomas Engineering Group, dated stamped received 10/24/2025, 3 sheets (A101, A102 and A201) entitled "Biscayne Automotive", prepared by SPARC+ Architecture Studio, dated stamped received 4/1/2025 and 4 sheets (TD-1, TD-2, LA-1, and LA-2) entitled "Biscayne Center", prepared by Dixie Landscape, dated stamped received 10/24/2025, for a total of 9 sheets. Except as may be specified by any zoning resolution applicable to the subject property, any future modifications on the property which conform to zoning code requirements will not require further public hearing action."

The purpose of request #1 is to modify conditions to allow the submittal of a new site plan for the property to redevelop a portion of the Property with a new and used automobile dealership.

- (3) NON-USE VARIANCE to permit a lot coverage of 48.3% (40% maximum permitted).
- (4) NON-USE VARIANCE to permit a Floor Area Ratio of 1.36 (1.17 maximum permitted).
- (5) NON-USE VARIANCE to permit 461 parking spaces (516 parking spaces required).
- (6) NON-USE VARIANCE to permit a greenbelt varying from 10.88' to 52.43' in width along the front property line abutting a right-of-way (minimum 15' wide greenbelt along the front property line abutting a right-of-way required).

The aforementioned plans are on file and may be examined in the Department of Regulatory and Economic Resources. Plans may be modified at public hearing.

**PROJECT HISTORY AND DESCRIPTION:**

Pursuant to Resolution #4-ZAB-317-82, the subject property was approved, with conditions, for the expansion of an existing office building, including increased lot coverage and floor area beyond that permitted by Code, modifications to required setbacks, and a waiver of the requirement to construct a five (5)-foot-high decorative masonry wall along the western property line. In 1992, pursuant to Resolution #4-ZAB-10-92, the property received additional approvals to permit a lounge in connection with a proposed restaurant, an unusual use to allow outdoor dining, and several non-use variances, including a reduction in required parking, a reduced separation distance from another business with alcoholic beverage uses, permission for live entertainment, and approval to serve alcoholic beverages during extended hours and without the requirement of meals. The restaurant approved under Resolution No. 4-ZAB-10-92 was located on the ground floor and occupied a portion of the area where the proposed automobile showroom will be located; therefore, the restaurant use will no longer exist on the subject property, and any future restaurant or similar use would require a modification to the approved plans.

The applicant now seeks approval to permit a new and used automobile dealership within the existing building located on the subject site, and to modify prior resolutions to allow the submittal of a new site plan to convert a portion of the existing enclosed office building into a new and used automobile dealership (Requests #1 and #2). In conjunction with these requests, the applicant also seeks approval of ancillary non-use variances to permit 461 parking spaces where 516 are required and 426 parking spaces were previously approved; to allow lot

coverage of 48.3% where a maximum of 40% is permitted and 44.4% was previously approved; to permit a floor area ratio (FAR) of 1.36 where a maximum FAR of 1.17 is permitted and 1.32 was previously approved; and to allow a greenbelt with a width varying from 10.88 feet to 52.43 feet along the front property line abutting a right-of-way where a minimum 15-foot-wide greenbelt is required (Requests #3 through #6). Proposed uses consist of office, showroom and service shop area.

<b>NEIGHBORHOOD CHARACTERISTICS</b>		
	<b>Zoning and Existing Use</b>	<b>Land Use Designation</b>
<b>Subject Property</b>	BU-2; office building	Business and Office
<b>North</b>	BU-2; office building	Business and Office
<b>South</b>	BU-2; commercial building	Business and Office
<b>East</b>	City of North Miami; shopping center	Business and Office
<b>West</b>	RU-4M; multi-family apartments	Medium Density Residential (13 to 25 DU/A)

**NEIGHBORHOOD COMPATIBILITY:**

The subject property is zoned BU-2 and is developed with an eight (8) story office building and a five (5) story parking garage with a connecting one-story building. To the north, properties are zoned BU-2 and are developed with office buildings; to the south, properties are zoned BU-2 and are developed with retail uses. To the east, within the City of North Miami, the property is developed as a shopping center. To the west, properties are zoned RU-4M and are developed with multi-family apartment buildings.

**SUMMARY OF THE IMPACTS:**

The approval of this application will allow the applicant to convert a portion of the office building into a new and used automobile dealership along with ancillary non-use variances that are not out of character with the area. Staff opines that based on the memoranda submitted by the departments reviewing the application, approval of the conversion of approximately 2,355 square feet of the existing eight (8) story building to a car dealership showroom area, an expansion of a service drive canopy area to the west of the existing building, and a five-bay 2,227 square foot automobile service shop will not create any new impacts on County resources in the surrounding area. Additionally, the Platting and Traffic Review Section of the Department of Regulatory and Economic Resources (RER) does not object to the application and has determined that it satisfies the applicable traffic concurrency criteria, generating approximately 32 additional PM peak-hour vehicle trips consistent with the Initial Development Order.

**COMPREHENSIVE DEVELOPMENT MASTER PLAN ANALYSIS:**

The subject property is designated as ***Business and Office*** on the Comprehensive Development Master Plan (CDMP) Land Use Plan (LUP) map. This *category accommodates the full range of sales and service activities. Included are retail, wholesale, personal and professional services, call centers, commercial and professional offices, hotels, motels, hospitals, medical buildings, nursing homes, entertainment and cultural facilities, amusements and commercial recreation establishments.* The approval of the requests sought in this

application with accompanying variances will permit the applicant to convert a portion of the property with a new and used automobile dealership.

Approval of the application will modify the specific use on the subject property; however, the proposed automobile dealership use remains within the range of permitted uses under the Business and Office designation on the CDMP Future Land Use Map. Therefore, staff opines that the approval would be **consistent** with the **Business and Office** CDMP LUP map designation, the CDMP Land Use Element Interpretative text for **Business and Office**.

### **ZONING ANALYSIS:**

The subject property consists of a ±2.74-acre parcel located along Biscayne Boulevard, a well-traveled major roadway. The property abuts similar office and commercial uses to the north, south, and east and is situated within a corridor characterized by a concentration of automobile dealerships and other commercial uses. Several existing car dealerships are located along Biscayne Boulevard within close proximity to the subject site, including Lexus of North Miami (approximately 1.6 miles north), Palmetto Alfa Romeo Fiat (approximately 1.3 miles north), Warren Henry INFINITI (approximately 2.0 miles northeast), Audi North Miami (approximately 2.0 miles northeast), Toyota of North Miami (approximately 3.5 miles northwest), Honda of Aventura (approximately 4.5 miles northeast), and Tropical Chevrolet in Miami Shores (approximately 4.8 miles south). The presence of these dealerships along the corridor reflects the established commercial character of Biscayne Boulevard and supports the compatibility of the proposed use within the surrounding area.

When analyzing request #1, to permit the conversion of a portion of the existing office building ground floor into a new and used car dealership under Section 33-311(A)(3), Special Exception, Unusual Uses and New Uses, along with the analysis of the ancillary requests to modify a condition of prior resolutions (requests #2), under Section 33-311 (A)(7), Generalized Modification Standards in staff's opinion, will not generate excessive traffic, provoke excessive overcrowding of people, tend to provoke a nuisance, and would be **compatible** with the area.

Staff notes that the purpose of the Special Exception and modification is to allow the applicant to submit plans proposing the conversion of approximately 2,355 square feet of ground-floor area within the existing eight (8)-story building into a car dealership showroom located along the east property line fronting Biscayne Boulevard, as well as a service drive canopy area and the construction of a five-bay, 2,227-square-foot automobile service shop, both to be located to the rear (west) of the existing building, to support the proposed use. The submitted plans also indicate site improvements along Biscayne Boulevard, including the addition of ground-floor fenestration and enhancements to the existing greenbelt along the front property line. Parking will primarily be accommodated within the existing structured parking garage located to the rear of the property. Staff finds that the proposed dealership use will not create new adverse visual impacts on the surrounding BU-2-zoned properties to the north, south, and east, which are developed with office and commercial uses, nor on motorists and pedestrians along adjacent roadways. The development provides a greenbelt ranging from 10.88 feet to 52.43 feet along the frontage adjacent to Biscayne Boulevard, with only a small portion along the southeastern frontage not meeting the required 15-foot minimum width. Additionally, staff will incorporate a condition prohibiting the outdoor display of new or used automobiles along Biscayne Boulevard. With respect to the existing multi-family development to the west, staff notes that the proposed service drive canopy and the five-bay, 2,227-square-foot automobile service shop will be buffered by a 24.9-foot-wide greenbelt with ample landscaping, in addition to the existing sidewalks and drive aisles that further separate the uses.

Further staff notes that the Platting and Traffic Review Section of the Department of Regulatory and Economic Resources (RER) memorandum states that the application will generate an additional 32 PM peak hour vehicle trips and meets the traffic concurrency criteria for an initial development order. Also, the Department of Regulatory and Economic Resources Environmental Review indicates that approval of this application meets all applicable LOS standards for an initial development order, as specified in the CDMP for potable water service, wastewater disposal, and flood protection. Additionally, the memorandum from the Miami-Dade Fire Rescue Department does not indicate that the proposed dealership expansion will have a negative impact on fire rescue services in the area. Based on the aforementioned memoranda, staff opines that approval of the subject request will not have an unfavorable effect on the economy of Miami-Dade County, Florida. Further, approval would not generate or result in excessive noise or traffic, cause undue or excessive burden on public facilities, including water, sewer, solid waste disposal, recreation, transportation, streets, roads, highways or other such facilities which have been constructed, or which are planned and budgeted for construction.

Based on the aforementioned analysis, staff opines that approval of the special exception and modification to prior resolutions, which would allow the applicant the conversion of approximately 2,355 square feet of ground-floor area within the existing eight (8)-story building into a car dealership showroom located along the east property line fronting Biscayne Boulevard, as well as a service drive canopy area and the construction of a five-bay, 2,227-square-foot automobile service shop, both to be located to the rear (west) of the existing building, to support the proposed use (request #1) along with the modification of a condition of prior resolutions, to allow for submittal of revised plans showing said car dealership (requests #2), will be **compatible** with the surrounding commercial and residential development. **Therefore, staff recommends approval with conditions of requests #1 under Section 33-311(A)(3), Special Exception, Unusual use and New Uses, and requests #2, under Section 33-311(A)(7), Generalized Modification Standards.**

When analyzing requests #3 through #6, under Section 33-311(A)(4)(b), the Non-Use Variance (NUV) Standards, staff is of the opinion that approval of the aforementioned requests will maintain the basic intent and purpose of the zoning, subdivision, and other land use regulations, which is to protect the general welfare of the public, particularly as it affects the stability and appearance of the community, and that the request will be otherwise **compatible** with the surrounding land uses and would not be detrimental to the community. The applicant seeks to permit 461 parking spaces where 516 are required and 426 parking spaces were previously approved where 474 parking spaces were required (request #3); to allow lot coverage of 48.3% where a maximum of 40% is permitted and 44.4% was previously approved (request #4); to permit a floor area ratio (FAR) of 1.36 where a maximum FAR of 1.17 is permitted and 1.32 was previously approved (request #5); and to allow a greenbelt varying from 10.88 feet to 52.43 feet in width along the front property line abutting a right-of-way where a minimum 15-foot-wide greenbelt is required (request #6). Staff notes that required parking is calculated based on the specific uses proposed within the building and has been recalculated to reflect the proposed dealership, showroom, office, and service shop components. The restaurant use approved in 1992 generated a higher parking requirement than the proposed showroom use; therefore, although the required parking has been recalculated based on the current proposal, the overall parking demand is comparable, and the requested variance represents only a minimal deviation from prior approvals. For example, Resolution No. 4-ZAB-10-92 granted a reduction of 48 parking spaces, whereas the current request reflects a reduction of 55 parking spaces, representing a difference of only seven (7) spaces. The requested lot coverage represents a 3.9% increase over the previously approved 44.4%, and the proposed FAR represents a 0.04

increase over the previously approved 1.32 FAR. With respect to the greenbelt, the portion measuring less than 15 feet occurs only along a limited segment of the southern frontage and is attributable to the irregular configuration of the building constructed in the 1980s. On average, the existing greenbelt exceeds 25 feet in width, which significantly surpasses the minimum 15-foot requirement. Additionally, the proposed plans contemplate enhancements to the existing landscaped areas, particularly along the western property line, to further buffer the site from adjacent uses and improve the overall aesthetic quality of the property. Staff also notes that the existing building will remain and is consistent in scale and massing with adjacent development, particularly the building to the north, which was previously approved with similar variances. **As such, staff recommends approval with conditions of requests #3 through #6, under Section 33-311(A)(4)(b), NUV Standards.**

**ACCESS, CIRCULATION AND PARKING:** The submitted plans indicate two (2) ingress/egress driveways from Biscayne Boulevard and one (1) ingress/egress driveway from NW 16 Avenue. In addition to the structured parking garage located on the western portion of the parcel, existing surface parking spaces surrounding the building along Biscayne Boulevard will remain.

**NEIGHBORHOOD SERVICES PROVIDER COMMENTS:** See attached.

**OTHER:** N/A

**RECOMMENDATION:**

**Approval with conditions.**

**CONDITIONS FOR APPROVAL:**

1. That a site plan be submitted to and meet with the approval of the Director of the Department of Regulatory and Economic Resources upon the submittal of an application for a building permit and/or Certificate of Use; said plan must include among other things but not be limited to, location of structure or structures, exits and entrances, drainage, walls, fences, landscaping, etc.
2. That in the approval of the plan, the same be substantially in accordance with that submitted for the hearing entitled "Biscayne Center Improvements" consisting of 2 sheets (C-1 and EX-1), prepared by Thomas Engineering Group, dated stamped received 10/24/2025, 3 sheets (A101, A102 and A201) entitled "Biscayne Automotive", prepared by SPARC+ Architecture Studio, dated stamped received 4/1/2025 and 4 sheets (TD-1, TD-2, LA-1, and LA-2) entitled "Biscayne Center", prepared by Dixie Landscape, dated stamped received 10/24/2025, for a total of 9 sheets. Except as may be specified by any zoning resolution applicable to the subject property, any future modifications on the property which conform to zoning code requirements will not require further public hearing action.
3. That all the other conditions of Resolution #4-ZAB-317-82, passed and adopted by the Metropolitan Dade County Zoning Appeals Board, last modified by Resolution #4-ZAB-10-92, remain in full force and effect except as herein modified.
4. That the use be established and maintained in accordance with the approved plan.

5. That the applicant submits to the Department for its review and approval a landscaping plan which indicates the type and size of plant material prior to the issuance of a building permit and to be installed prior to the issuance of a Certificate of Use.
6. That no stringer lights, pennants, mobile or stationary visual devices, except as permitted under point-of-sale sign regulations, shall be used or displayed.
7. That no outdoor display of new or used automobiles shall be permitted on the subject property.
8. That no outdoor automobile or truck repairs shall be permitted on the premises.
9. That the applicant obtains a Certificate of Use from the Department, upon compliance with all terms and conditions, the same subject to cancellation upon violation of any of the conditions.
10. That the applicant complies with all applicable conditions and requirements from the Miami-Dade County Department of Transportation and Public Works (DTPW) Traffic Engineering Division as indicated in the attached memorandum.
11. That the applicant complies with all applicable conditions and requirements from the Platting and Traffic Section of the Department of Regulation and Economic Resources (RER) as indicated in the attached memorandum.
12. That the applicant complies with all applicable conditions and requirements from the Miami-Dade Water and Sewer Department as indicated in the attached memorandum.

ES:JB:SS:EA

*Eric Silva*

---

Eric Silva, AICP, Assistant Director  
Development Services Division  
Miami-Dade County Department of  
Regulatory and Economic Resources

# ZONING RECOMMENDATION ADDENDUM

Biscayne Real Estate Holdings, LLC.  
PH: Z24-192

<b>NEIGHBORHOOD SERVICES PROVIDER COMMENTS</b>	
<i>Building and Neighborhood Compliance</i>	<i>No objection</i>
Department of Regulatory and Economic Resources Environmental Review	<i>No objection</i>
<i>Water and Sewer Department</i>	<i>No objection*</i>
<i>Platting and Traffic Review Section (RER)</i>	<i>No objection*</i>
<i>Fire Rescue</i>	<i>No objection</i>
<i>Transportation and Public Works (DTPW) Traffic Engineering Division</i>	<i>No objection*</i>
<i>*Subject to conditions in their memorandum.</i>	

## COMPREHENSIVE DEVELOPMENT MASTER PLAN (CDMP) OBJECTIVES, POLICIES AND INTERPRETATIVE TEXT

<p><b>Business and Office</b> <b>(Page I-40)</b></p>	<p><i>This category accommodates the full range of sales and service activities. Included are retail, wholesale, personal and professional services, call centers, commercial and professional offices, hotels, motels, hospitals, medical buildings, nursing homes (also allowed in the institutional category), entertainment and cultural facilities, amusements and commercial recreation establishments such as private commercial marinas. Also allowed are telecommunication facilities (earth stations for satellite communication carriers, satellite terminal stations, communications telemetry facilities and satellite tracking stations). These uses may occur in self-contained centers, high-rise structures, campus parks, municipal central business districts or strips along highways. In reviewing zoning requests or site plans, the specific intensity and range of uses, and dimensions, configuration and design considered to be appropriate will depend on locational factors, particularly compatibility with both adjacent and adjoining uses, and availability of highway capacity, ease of access and availability of other public services and facilities. Uses should be limited when necessary to protect both adjacent and adjoining residential use from such impacts as noise or traffic, and in most wellfield protection areas uses are prohibited that involved the use, handling, storage, generation or disposal of hazardous material or waste, and may have limitations as to the maximum buildable area, as defined in Chapter 24 of the County Code. When the land development regulations are amended pursuant to Land Use Element Policies LU-9P and LU-9Q, live-work and work-live developments shall be permitted on land designated as Business and Office, as transitional uses between commercial and residential areas.</i></p> <p><i>Residential uses, and mixing of residential use with commercial, office and hotels are also permitted in Business and Office areas provided that the scale and intensity, including height and floor area ratio of the residential or mixed use development, is not out of character with that of adjacent or adjoining development and zoning, and it does not detrimentally impact, and it provides a sensitive well designed transition to any adjacent or adjoining residentially developed or designated areas of different development intensity. Where these conditions are met residential development may be authorized to occur in the Business and Office category at a density up to one density category higher than the LUP-designated density of the adjacent or adjoining residentially designated area on the same side of the abutting principal roadway, or up to the density of any such existing residential development, or zoning if the adjacent or adjoining land is undeveloped, whichever is higher. If there is no adjacent or adjoining residential use existing, zoned or designated on the same side of the roadway, the maximum allowable residential density will be that which exists or which this plan allows across the roadway. Where there is no residential use, zoning or designation on either side of the roadway, the intensity of residential development, including height, bulk and floor area ratio shall be no greater than that which would be permitted for an exclusively commercial use of the site. Where SURs or TDRs are transferred to Business-designated parcels which are zoned or to be used for residential development, or when a residential project utilizes the inclusionary zoning program the allowances of the Residential communities section may be used within the limits provided in this paragraph.</i></p>
--	---

**PERTINENT ZONING REQUIREMENTS/STANDARDS**

<p><b>Sec. 33-247. - Uses permitted</b></p>	<p><i>(4) Automobile and light truck, new sales agency or rental shall be permitted only upon approval after public hearing and subject to the following conditions: (a) That a continuous, densely planted greenbelt of not less than fifteen (15) feet in width, penetrated only at points approved by the Director and the Director of the Public Works Department for ingress or egress to the property, shall be provided along all property lines abutting public rights-of-way or properties zoned residential. Said greenbelt shall have shade trees planted at a maximum spacing of thirty (30) feet on center. The shade trees shall have a minimum caliper of two and one-half (2½) inches at time of planting.</i></p>
<p><b>Sec. 33-253.3. - Floor area ratio and lot coverage</b></p>	<p><i>The floor area ratio shall be forty-one-hundredths (0.40) at one (1) story and shall be increased by eleven-one-hundredths (0.11) for each additional story up to eight (8) stories, thereafter the floor area ratio shall be increased by six-one-hundredths (0.06) for each additional story. Structure parking shall not count as part of the floor area but shall be counted in computing building height and number of stories. The total lot coverage permitted for all buildings on the site shall not exceed forty (40) percent of the total lot area. Enclosed or nonenclosed mall areas shall not count as part of the floor area, for floor area ratio computation purposes, nor as part of the lot coverage.</i></p>
<p><b>Section 33-311(A)(7) Generalized Modification Standards.</b></p>	<p><i>The Board shall hear applications to modify or eliminate any condition or part thereof which has been imposed by any final decision adopted by resolution; and to modify or eliminate any provisions of restrictive covenants, or parts thereof, accepted at public hearing, except as otherwise provided in Section 33-314(C)(3); provided, that the appropriate Board finds after public hearing that (a) the modification or elimination, in the opinion of the Community Zoning Appeals Board, would not generate excessive noise or traffic, tend to create a fire or other equally or greater dangerous hazard, or provoke excessive overcrowding of people, or would not tend to provoke a nuisance, or would not be incompatible with the area concerned, when considering the necessity and reasonableness of the modification or elimination in relation to the present and future development of the area concerned, or (b) (i) that the resolution that contains the condition approved a school use that was permitted only as a special exception, (ii) that subsequent law permits that use as of right without the requirement of approval after public hearing, and (iii) that the requested modification or elimination would not result in development exceeding the standards provided for schools authorized as a matter of right without the requirement of approval after public hearing.</i></p>
<p><b>Section 33-311(A)(3) Special Exception, Unusual and New Uses</b></p>	<p><i>Special exceptions (for all applications other than public charter schools), unusual and new uses. Hear application for and grant or deny special exceptions, except applications for public charter schools; that is, those exceptions permitted by the regulations only upon approval after public hearing, new uses and unusual uses which by the regulations are only permitted upon approval after public hearing; provided the applied for exception or use, including exception for site or plot plan approval, in the opinion of the Community Zoning Appeals Board, would not have an unfavorable effect on the economy of Miami-Dade County, Florida, would not generate or result in excessive noise or traffic, cause undue or excessive burden on public facilities, including water, sewer, solid waste disposal, recreation, transportation, streets, roads, highways or other such facilities which have been constructed or which are planned and budgeted for construction, are accessible by private or public roads, streets or highways, tend to create a fire or other equally or greater dangerous hazards, or provoke excessive overcrowding or concentration of people or population, when considering the necessity for and reasonableness of such applied for exception or use in relation to the present and future development of the area concerned and the compatibility of the applied for exception or use with such area and its development.</i></p>
<p><b>Section 33-311(A)(4)(b) Non-Use Variances From Other Than Airport Regulations</b></p>	<p><i>Upon appeal or direct application in specific cases, the Board shall hear and grant applications for non-use variances from the terms of the zoning and subdivision regulations and may grant a non-use variance upon a showing by the applicant that the non-use variance maintains the basic intent and purpose of the zoning, subdivision and other land use regulations, which is to protect the general welfare of the public, particularly as it affects the stability and appearance of the community and provided that the non-use variance will be otherwise compatible with the surrounding land uses and would not be detrimental to the community. No showing of unnecessary hardship to the land is required.</i></p>

**Building and Neighborhood Compliance**

**ENFORCEMENT HISTORY**

BISCAYNE REAL ESTATE HOLDINGS, LLC      11900 BISCAYNE BLVD  
MIAMI-DADE COUNTY, FLORIDA.

---

**APPLICANT**

**ADDRESS**

Pending

Z2024000192

---

**DATE**

**HEARING NUMBER**

**FOLIO: 30-2229-096-0010**

**REVIEW DATE OF CURRENT ENFORCEMENT HISTORY:**

November 7, 2025

**NEIGHBORHOOD REGULATIONS:**

There are no open/closed cases in CMS.

**BUILDING SUPPORT REGULATIONS:**

**Case No. 20240228770B** was opened on 03/19/2024. A Notice of Violation was issued on 03/19/2024 for "Failure to obtain required building permit(s) prior to commencing work on: Interior buildout/commercial remodel of building suite to include Building, plumbing, electrical and mechanical trades. (front glass doors and dividing glass barriers, room buildouts, lavatories, lighting, A/C ducts to rooms, rear lavatory, tankless water heater, electrical junction box, washer, and dryer.)" Since compliance was not met, Civil Violation Notice **P068685** was issued on 05/12/2025 for "SECTION 105.1 OF THE FLORIDA BUILDING CODE: FAILURE OF OWNER-BUILDER OR CONTRACTOR TO OBTAIN A PERMIT PRIOR TO COMMENCING WORK on Interior buildout/commercial remodel of building suite to include Building, plumbing, electrical and mechanical trades. (Front glass doors and dividing glass barriers, room buildouts, lavatories, lighting, A/C ducts to rooms, rear lavatory, tankless water heater, electrical junction box, washer, and dryer.)". Citation was paid on 05/21/2025, **and the assessed penalties are on appeal.**

**Case No. B2024001101F** was opened on 02/01/2025. Citation **P060097** was issued on 02/01/2025 for "FAILURE TO OBTAIN A BUILDING RECERTIFICATION." Citation was paid on 05/12/2025,

however a Final Notice of Intent to Lien and Demand for payment was issued on 09/11/2025. A Settlement payment was received on 10/17/2025. **The settlement agreement is valid through 04/20/2026.**

**Case No. A2025001215** was opened on 01/11/2025. A Notice of Violation was issued on 01/14/2025 for the expiration of permit no. 2024038841. Since compliance was not met, Civil Violation Notice **P068686** was issued on 05/12/2025 for *"FAILURE TO MAINTAIN A BUILDING OR STRUCTURE IN A SAFE CONDITION OR FAILURE TO MAINTAIN DEVICES OR SAFEGUARDS IN GOOD WORKING ORDER DUE TO FAILURE TO OBTAIN MANDATORY INSPECTIONS FOR THE SCOPE OF WORK UNDER PERMIT NUMBER 2024038841."* Compliance was met on 07/15/2025 and cvn paid on 08/08/2025. **Case is closed.**

**VIOLATOR:**

BISCAYNE REAL ESTATE HOLDINGS, LLC

**OUTSTANDING LIENS AND FINES:**

There are no outstanding liens or fines.

# Memorandum

**Date:** February 23, 2026

**To:** Lourdes M. Gomez, AICP, Director  
Department of Regulatory and Economic Resources

**From:** Christine Velazquez, Division Chief  
Department of Regulatory and Economic Resources (RER)

**Subject:** Z2024000192-3<sup>rd</sup> Review  
Biscayne Real Estate Holdings, LLC  
11900 Biscayne Boulevard  
(1) Special exception to permit the automobile dealership and showroom including an expansion of a service drive canopy area, and an automobile service shop as permitted within the BU-2 District  
(2) Modification of Resolution No. 4-ZAB-10-92 (the "Resolution") in order to revise the approved site plan under the Resolution.  
(3) NUVs for off-tree parking requirements, lot coverage requirements, max FAR requirements and greenbelt requirements.  
(BU-2) (2.74 acres)  
29-52-42

---

The Department of Regulatory and Economic Resources, Code Coordination and Public Hearings has reviewed the above-referenced zoning application for compliance with the requirements of Chapter 24 of the Miami-Dade County Code (the Code) for potable water service and wastewater disposal. Based on the information provided, this zoning application is approved pursuant to section 24-43.1 of the Code related to potable water supply and wastewater disposal.

#### Potable Water Supply and Wastewater Disposal

Based on RER records, the subject property is currently connected to public water and sanitary sewers. Pursuant to the Code and based on the site plan submitted in support of this application, the proposed development is within feasible distance to connect to public water and public sanitary sewer. Therefore, the proposed development shall connect to public water and sanitary sewers in accordance with Code requirements. Public water and sewer services are provided by the City of North Miami. To the extent that connection to the public sanitary sewer system is not approved due to a sanitary sewer moratorium, this memorandum shall not be interpreted as written approval from DERM to allow an alternative means of domestic wastewater disposal.

Existing public water and sewer facilities and services meet the Level of Service (LOS) standards set forth in the Comprehensive Development Master Plan (CDMP). Furthermore, the proposed development order, if approved, will not result in a reduction in the LOS standards subject to compliance with the conditions required by DERM for this proposed development order.

Please note that some of the collection/transmission facilities, which include sanitary sewer gravity sewer mains, sanitary sewer force mains and sanitary sewer pump stations, throughout the County do not have adequate capacity, as defined in the Consent Decree between Miami-Dade County, Florida Department of Environmental Protection, and the U.S. Environmental Protection Agency case 1:12-cv-24400-FAM. Under the terms of this Consent Decree, this approval does not constitute an allocation or certification of adequate treatment and transmission system capacity. At the time of building permits,

DERM will evaluate and may reserve sanitary sewer capacity through the DERM sanitary sewer certification process, if the proposed development complies with the provisions of the Consent Decree. Building permits for development in sanitary sewer basins that have been determined not to have adequate capacity cannot be approved until adequate capacity becomes available.

*Please be advised, DERM review and approval is required for any proposed public or private sanitary sewer system. Each parcel within the proposed development that is required to be served by public sanitary sewers shall connect directly to the public sanitary sewer system, without traversing other parcels. Private sanitary sewer collection and transmission systems are limited to one building per parcel connecting directly to a public sanitary sewer system and cannot traverse other parcels to connect to the public sanitary sewer system. If multiple buildings are within a parcel, each building shall connect individually to a public sanitary sewer system without traversing other parcels.*

**Conditions of Approval: None**

Water Control Review

Any development/ redevelopment involving 2 acres or more of impervious area shall require a DERM Surface Water Management General Permit for the construction and operation of the required surface water management system. This permit shall be obtained prior to any future development order approval. The applicant is advised to contact the DERM Water Control Section (305)372-6681 for further information regarding permitting procedures and requirements.

Stormwater shall be retained on site utilizing designed seepage or infiltration drainage system. Drainage plans shall provide for full on-site retention of the stormwater runoff generated by a 25-year, 3-day storm event per section 24.42.8(4)(i) of the Code.

Any proposed development shall comply with county and federal flood criteria requirements. The proposed development order, if approved, will not result in a reduction in the LOS standards for flood protection set forth in the CDMP subject to compliance with the conditions required for this proposed development order.

**Conditions of Approval: None**

Tree Preservation

An aerial review of the subject property indicates the presence of tree resources. . Section 24-49 of the Code provides for the preservation and protection of tree resources.

A Miami-Dade County Tree Permit is required prior to the removal and/or relocation of any tree that is subject to the tree preservation and protection provisions of the Code. The applicant is advised that a tree survey that includes a tree disposition table will be required during the tree removal permit application process. Projects and permits shall comply with the requirements of sections 24-49.2 and 24-49.4 of the Code, including the specimen tree standards.

In accordance with section 24-49.9 of the Code, all plants prohibited by Miami-Dade County shall be removed from all portions of the property prior to development, or redevelopment and developed parcels shall be maintained to prevent the growth or accumulation of prohibited species. Please contact Jackelyn

Alberdi at Jackelyn.Alberdi@miamidade.gov regarding any additional information or concerns with this review.

### **Conditions of Approval: None**

#### DERM Enforcement History Review

There are no open or closed enforcement records for violations of Chapter 24 of the Code for the subject property. There are no outstanding DERM liens or fines for the subject property.

#### Air Quality Preservation

The following advisory information is included in case demolition, or renovation activities will take place as part of the proposed development: 40 CFR Part 61 Subpart M - National Emission Standards for Hazardous Air Pollutants (NESHAP) for Asbestos provides that an asbestos survey from a Florida-licensed asbestos consultant is required is required for renovation activities surpassing the NESHAP threshold of suspect regulated asbestos containing materials (RACM), and for all demolition activities.

“Demolition” is defined as the wrecking or taking out of any load-supporting structural member of a facility together with any related handling operations, or the intentional burning of any facility.

The NESHAP thresholds for RACM are 260 linear feet of RACM on pipes, or 160 square feet of RACM on other facility components.

If the Asbestos Survey identifies materials (friable or to be made friable during the proposed renovation/demolition activities) containing more than 1 percent asbestos and the amount is over the regulated thresholds, then those materials must be removed/abated prior to renovation/demolition activities by a Florida-licensed asbestos abatement contractor. An Asbestos Renovation Notification must be filed, and obtain approval, with the Miami Dade County - Department of Regulatory and Economic Resources, Division of Environmental Resources Management - Air Quality Management (AQM), at least 10 working days (14 calendar days) prior to starting the abatement work. Regardless of asbestos content, prior to any demolition work, an Asbestos Demolition Notification must be submitted and approved, within the same timeframes.

For question regarding asbestos surveys and notifications, please contact the AQMD via email at [asbestos@miamidade.gov](mailto:asbestos@miamidade.gov).

#### Concurrency Review Summary

A concurrency review has been conducted for this application and DERM has determined that the same meets all applicable LOS standards for an initial development order as specified in the adopted CDMP for potable water supply, wastewater disposal, and flood protection. This concurrency approval is valid only for this initial development order. Pursuant to Chapter 33G of the Code, a final concurrency statement will be issued at the time of final development order.

If you have any questions concerning the comments or wish to discuss this matter further, please contact Ninfa Rincon at (305) 372-6764.

cc: Eric Silva, Department of Regulatory and Economic Resources

# Memorandum



**Date:** July 8, 2025

**To:** Eric Silva, AICP, Assistant Director  
Development Services Division  
Department of Regulatory and Economic Resources (RER)

**Through:** James B. Ferguson, P.E.  
Assistant Director  
Water and Sewer Department (WASD)

**From:** Maria A. Valdes, CSM, LEED® Green Associate  
Chief, Planning & Water Certification Section  
Water and Sewer Department

**Subject:** Zoning Application Comments - Biscayne Real Estate Holdings LLC  
Application No. Z2024000192 (Revision No. 2) - (Pre-App. No. Z24P-131)

*Maria Valdes*

---

The Water and Sewer Department has reviewed the proposed development for the subject zoning application. WASD has no objections to this Zoning Application, based on the information provided. Additional requirements may be needed at the time of permitting. The information provided below is preliminary and it does not affect the Zoning process.

The subject application is within the City of North Miami's water and sewer service area. At the time of development, the applicant is advised to consult with the respective Utility for any infrastructure that they may have in their service area.

Application Name: Biscayne Real Estate Holdings LLC

Location: The proposed project is located at 11900 Biscayne Boulevard with Folio No. 30-2229-096-0010, in unincorporated Miami-Dade County.

Proposed Development: The applicant is proposing to redevelop a portion of the property with a new car dealership. The proposed site plan contemplates the conversion of approximately 2,355 square feet of the existing office building as a 2,355 square feet car dealership showroom area, an expansion of a service drive canopy area to the west of the existing building, and a new five bay 2,227 square feet automobile service shop.

The proposed development results in an increase in water demand of 89 per day (gpd).

Water: The proposed development is located within the City of North Miami's water service area, but the water is supplied by WASD. North Miami is a water wholesale customer of WASD. Please consult with the Utility Department of the City of North Miami for any infrastructure that they may have in their service area.

A Water Supply Certification (WSC) will be required from WASD for the proposed development. Said Certification will be issued at the time of development when a WASD Ordinance letter is issued. The WSC letter shall remain active in accordance with terms and conditions specified

in said certification. The WSC is required consistent with Policy CIE-5D and WS-2C in the County's CDMP and in accordance with the permitted withdrawal capacity in the WASD's 20-year Water Use Permit.

For more information on the Water Supply Certification Program please go to <http://www.miamidade.gov/water/water-supply-certification.asp>

In addition, all future development will be required to comply with water use efficiency techniques for indoor water use and with landscape standards in accordance with Sections 8-31, 32-84, 18-A and 18-B of the Miami-Dade County Code and consistent with Policies WS-5E and WS-5F of the CDMP.

For more information about our Water Conservation Program please go to <http://www.miamidade.gov/conservation/home.asp>

For information concerning the Water-Use Efficiency Standards Manual please go to <http://www.miamidade.gov/waterconservation/library/instructions/water-use-efficiency-standards-manual.pdf>

Sewer: The proposed development is located within the City of North Miami's sewer service area. Please consult with the Utility Department of the City of North Miami for any infrastructure that they may have in their service area.

North Miami is a Volume Sewer Customer of WASD. At the time of development, an Ordinance letter will be required from WASD. WASD will be the Utility providing sewer services for treatment and disposal of the wastewater at the North District Wastewater Treatment Plant (NDWWTP). The NDWWTP is currently operating under a permit from the Florida Department of Environmental Protection. Currently, there is adequate sewer treatment and disposal capacity at the NDWWTP, consistent with Policy WS-2 A (2) of the CDMP.

Connection to the sanitary sewer system is subject to the following conditions:

- Adequate transmission and plant capacity exist at the time of the owner's request consistent with policy WS-2 A (2) of the CDMP. Capacity evaluations of the plant for average flow and peak flows will be required. Connection to the COUNTY'S sewage system will be subject to the terms, covenants and conditions set forth in court orders, judgments, consent orders, consent decrees and the like entered into between the COUNTY and the United States, the State of Florida and/or any other governmental entity, including but not limited to, the Consent Order entered on April 9, 2014 in the United States of America, State of Florida and State of Florida Department of Environmental Protection v. Miami-Dade County, Case No. 1:12-cv-24400-FAM, as well as all other current, subsequent or future enforcement and regulatory actions and proceedings.

- Approval of all applicable governmental agencies having jurisdiction over these matters are obtained.

Should you have any questions, please contact Maria A. Valdes, Chief, Planning & Water Certification Section at (786) 552-8198 or [mavald@miamidade.gov](mailto:mavald@miamidade.gov), Alfredo B. Sanchez at (786) 552-8237 or [sanalf@miamidade.gov](mailto:sanalf@miamidade.gov), or Suyapa Carbajal at (786) 552-8124 or [suyapa.carbajal@miamidade.gov](mailto:suyapa.carbajal@miamidade.gov).

# Memorandum



Date: August 12, 2025

To: Eric Silva, AICP, Assistant Director  
Department of Regulatory and Economic Resources

From:  For: Raul A. Pino, PLS, Division Chief  
Platting and Traffic Review Section  
Department of Regulatory and Economic Resources

Subject: Z2024000192  
Name: Biscayne Real Estate Holdings  
Location: 11900 Biscayne Blvd.  
Section 29 Township 52 South Range 42 East

---

The Department of Regulatory and Economic Resources Platting and Traffic Review Section has reviewed the subject application and has **no objections**.

This land complies with Chapter 28 of the Miami-Dade County Code. The property is platted as Tract B, Plat Book 120, Page 65.

This application meets the traffic concurrency criteria because it lies within the urban infill area where traffic concurrency does not apply. The change in the development program from Office use to Office use and Auto Sales Dealership will generate approximately an additional 32(\*) PM peak hour vehicle trips.

The request herein, constitutes an Initial Development Order only, and one or more traffic concurrency determinations will subsequently be required before development will be permitted.

(\*) Trip generation based on applicant traffic study.

Notes: PM =Post Meridiem

The PM peak hour refers to the highest hour of vehicle trips generated during the afternoon peak hours of 4-6 PM

## Standard Conditions:

- A letter or a plan containing the following certification signed and sealed by a State of Florida registered engineer shall be submitted as part of the paving and drainage plans: "I hereby certify that the all of the roads for the subject project comply with all of the applicable portions of the Manual of Uniform Minimum Standards for Design, Construction and Maintenance for Streets and Highways (Florida Greenbook) regarding: design speed, lane widths, horizontal alignment, vertical alignment, stopping sight distance, sight distance, horizontal clearance, vertical clearance, superelevation, shoulder widths, grades, bridge widths, etc."
- All landscaping, walls, fences, entrance features, etc. will be subject to the Safe Sight Distance Triangle as per Section 33-11 of the Miami-Dade County Code and G5.3 of the Public Works and Waste Management Department Manual.

# Memorandum



**Date:** June 18, 2025

**To:** Eric Silva, Assistant Director  
Regulatory and Economic Resources

**From:** Alejandro G Cuello, Principal Planner  
Miami-Dade Fire Rescue Department

**Subject:** Z2024000192

---

The Miami-Dade Fire Rescue Department has **no objection** to request for non-use variances and modification uploaded to "EnerGov" on 6/16/2025. Proposed scope of modification does not affect previously approved fire department access.

MDFR's comments on this zoning application do not effectuate a change of occupancy classification for any existing building on the subject property. Changes of occupancy, if needed, must be achieved by a building permit application process in accordance with the provisions of the Florida Building Code and the Florida Fire Prevention Code.

For additional information, please contact [acuello@miamidade.gov](mailto:acuello@miamidade.gov) or call 305-775-3357.

# Memorandum



**Date:** Monday, February 23, 2026  
**Subject:** Review Type: Z2024000192  
 Applicant Name: Biscayne Real Estate Holdings LLC

Miami-Dade County Department of Transportation and Public Works (DTPW) Traffic Engineering Division has reviewed the subject application and has no objections to this application, subject to the conditions in Section I:

**PROJECT LOCATION:**

The property is located at 11900 Biscayne Boulevard in Miami Florida.

**COMMENTS/RECOMMENDATION:**

I. CONDITIONS:

- The proposed development seeks the conversion of approximately 2,301 square feet of the existing eight story building into a car dealership showroom area, an expansion of a service drive canopy area to the west of the existing building, and a five-bay 2,227 square foot automobile service shop for the intended use. In the case that the land use information is modified, a new site plan/traffic study must be submitted for review.
- Please ensure that all trees within the sight triangles must comply with the FDOT standards outlined in the "Tree Spacing Table" provided below

considered.

**TREE SPACING TABLE \*\***

Description	Design Speed (mph)													
	30		35		40		45		50		55		60	
Diameter (Within Limits of Sight Window)	(Inches)													
	>4≤11	>11≤18	>4≤11	>11≤18	>4≤11	>11≤18	>4≤11	>11≤18	>4≤11	>11≤18	>4≤11	>11≤18	>4≤11	>11≤18
Minimum Spacing (c. to c. of Trunk)	(Feet)													
	25	90	30	105	35	120	40	135	50	150	55	165	60	180

\*\* Sizes and spacings are based on the following conditions:  
 a. A single line of trees in the median parallel to but not necessarily colinear with the centerline.  
 b. A straight approaching mainline, within skew limits as described in No. 2 above.  
 c. 1. Trees and palms ≤ 11" in diameter casting a vertical 6' wide shadow band on a vehicle entering at stop bar location when viewed by mainline driver beginning at distance 'd'; see SHADOW DIAGRAM, Sheet 2.  
 2. Sabal palms with diameters > 11" ≤ 18" spaced at intervals providing a 2 second full view of entering vehicle at stop bar location when viewed by the mainline driver beginning at distance 'd'; see PERCEPTION DIAGRAM, Sheet 2.  
 d. Trees with diameters ≤ 11" intermixed with trees with diameters > 11" ≤ 18" are to be spaced based on trees with diameters > 11" ≤ 18".

- All property development adjacent to a State Road must be reviewed by the Florida Department of Transportation (FDOT) for compliance with the Florida Administrative Code (FAC). Improvements within the FDOT Right-of-Way (R/W) must meet current FDOT Design Standards and may involve a property dedication to meet current FDOT Standards. No below or above-ground encroachments are allowed into the FDOT R/W. Access/driveway spacing must meet the criteria in FAC 14-96, and a pre-application meeting with the FDOT is required for driveway categories C, D, E, F, and G. Also, per FAC 14-86.003, a Drainage permit is required for all properties adjacent to a State Road, even if there is no proposed access/driveway connection. Please contact the FDOT District 6 Permits Office for

FDOT permitting requirements/guidance: [d6permitshelp@dot.state.fl.us](mailto:d6permitshelp@dot.state.fl.us), (305) 470-5367.

**If you have any questions concerning the comments, or wish to discuss this matter further, please contact Anamersy Arce at [anamersy.arce@miamidade.gov](mailto:anamersy.arce@miamidade.gov).**

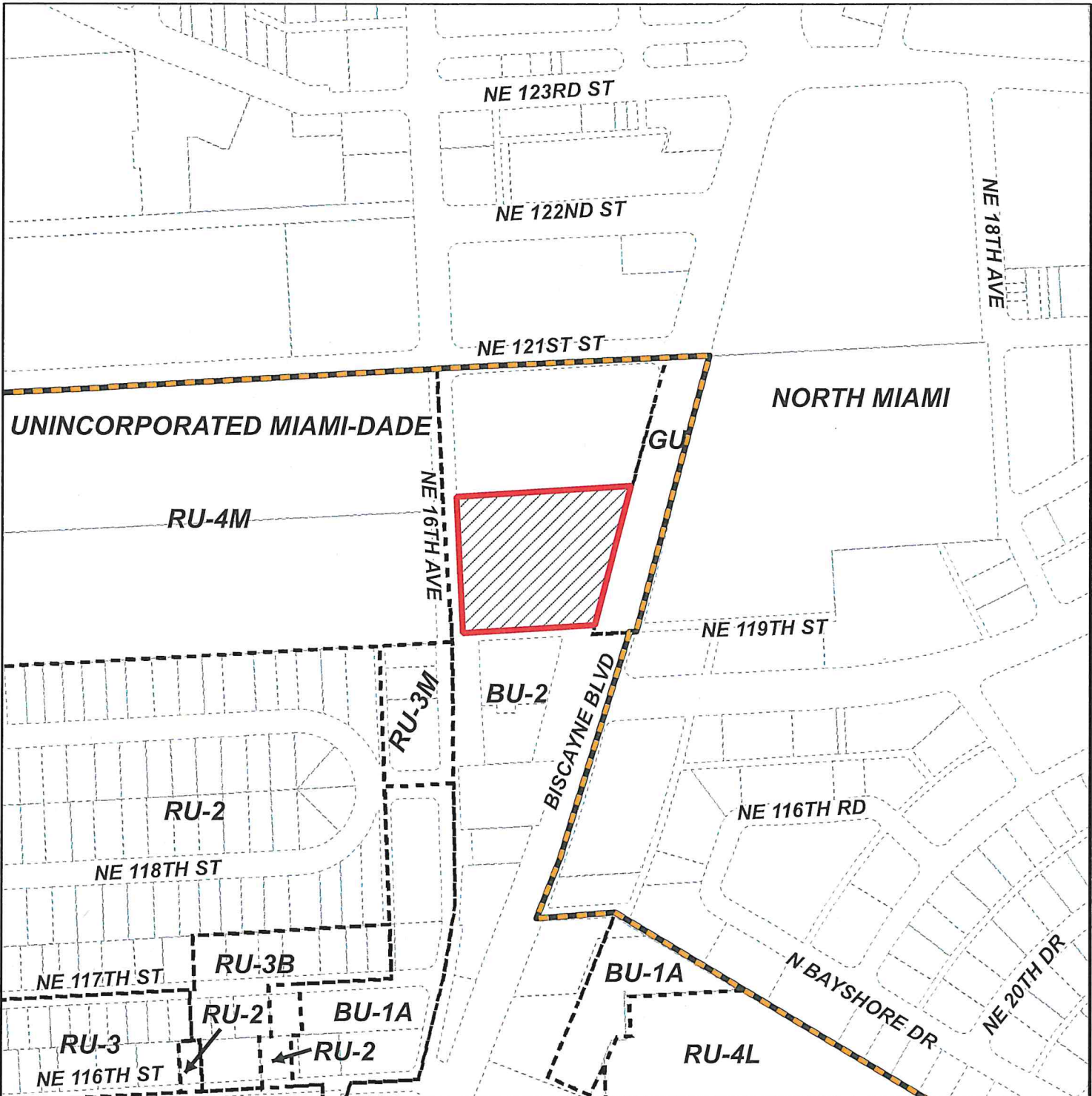



**MIAMI-DADE COUNTY**  
**HEARING MAP**

Process Number  
**Z2024000192**

Section: 29 Township: 52 Range: 42  
 Applicant: Biscayne Real Estate Holdings LLC LLC  
 Zoning Board: C7  
 Commission District: 4  
 Drafter ID: EDUARDO CESPEDES  
 Scale: NTS

**Legend**

-  Subject Property Case
-  Zoning



SKETCH CREATED ON: Thursday, September 12, 2024

REVISION	DATE	BY

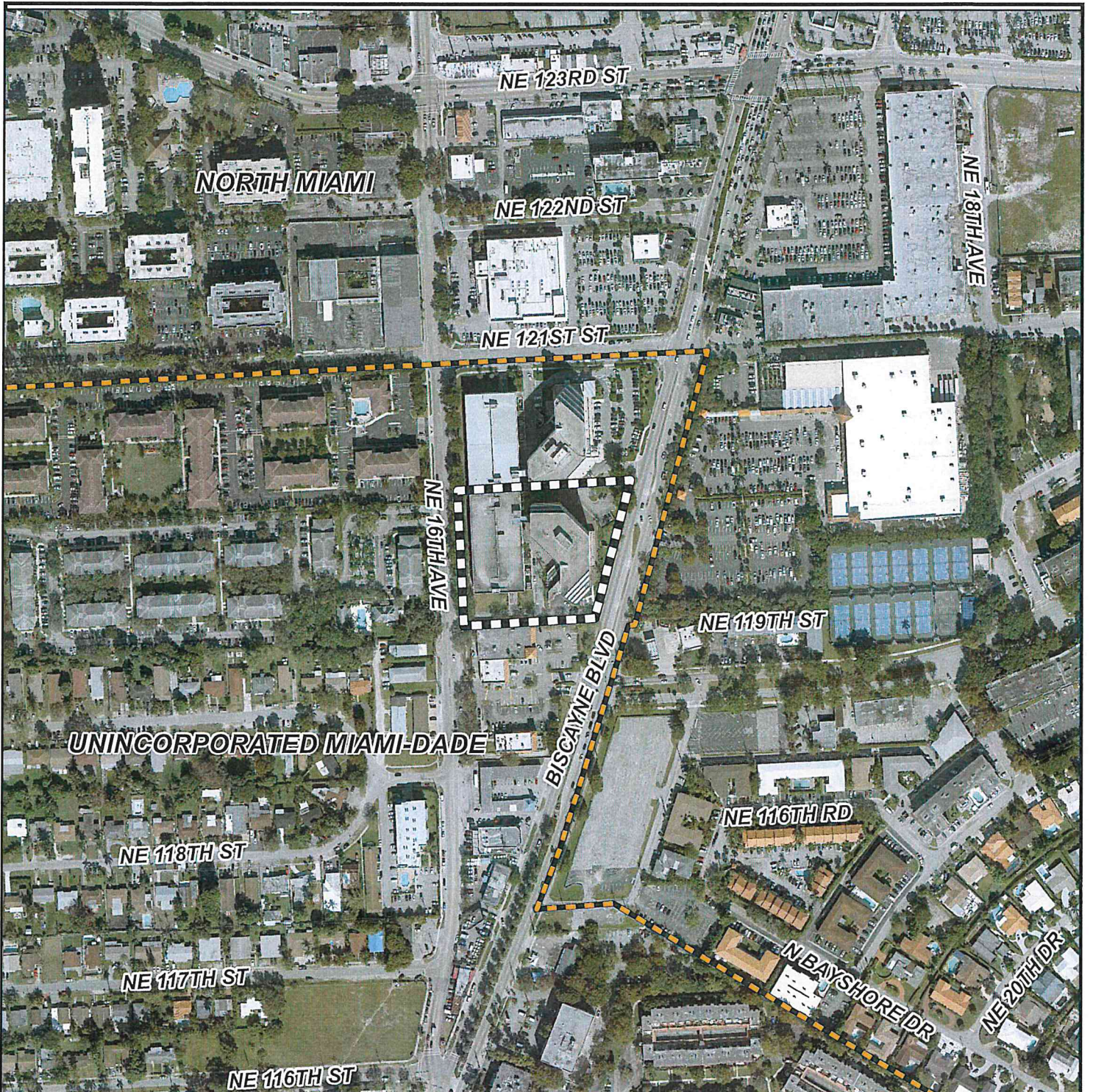



**MIAMI-DADE COUNTY**

**AERIAL YEAR 2023**

**Process Number**

**Z2024000192**

**Legend**

-  Subject Property
-  Municipalities



Section: 29 Township: 52 Range: 42  
 Applicant: Biscayne Real Estate Holdings LLC LLC  
 Zoning Board: C7  
 Commission District: 4  
 Drafter ID: EDUARDO CESPEDES  
 Scale: NTS



SKETCH CREATED ON: Thursday, September 12, 2024

REVISION	DATE	BY



**MIAMI-DADE COUNTY  
RADIUS MAP**

Process Number  
**Z2024000192**  
RADIUS: 2640

Section: 29 Township: 52 Range: 42  
Applicant: Biscayne Real Estate Holdings LLC LLC  
Zoning Board: C7  
Commission District: 4  
Drafter ID: EDUARDO CESPEDES  
Scale: NTS

**Legend**

-  Subject Property
-  Buffer
-  Municipalities
-  Property Boundaries



SKETCH CREATED ON: Thursday, September 12, 2024

REVISION	DATE	BY

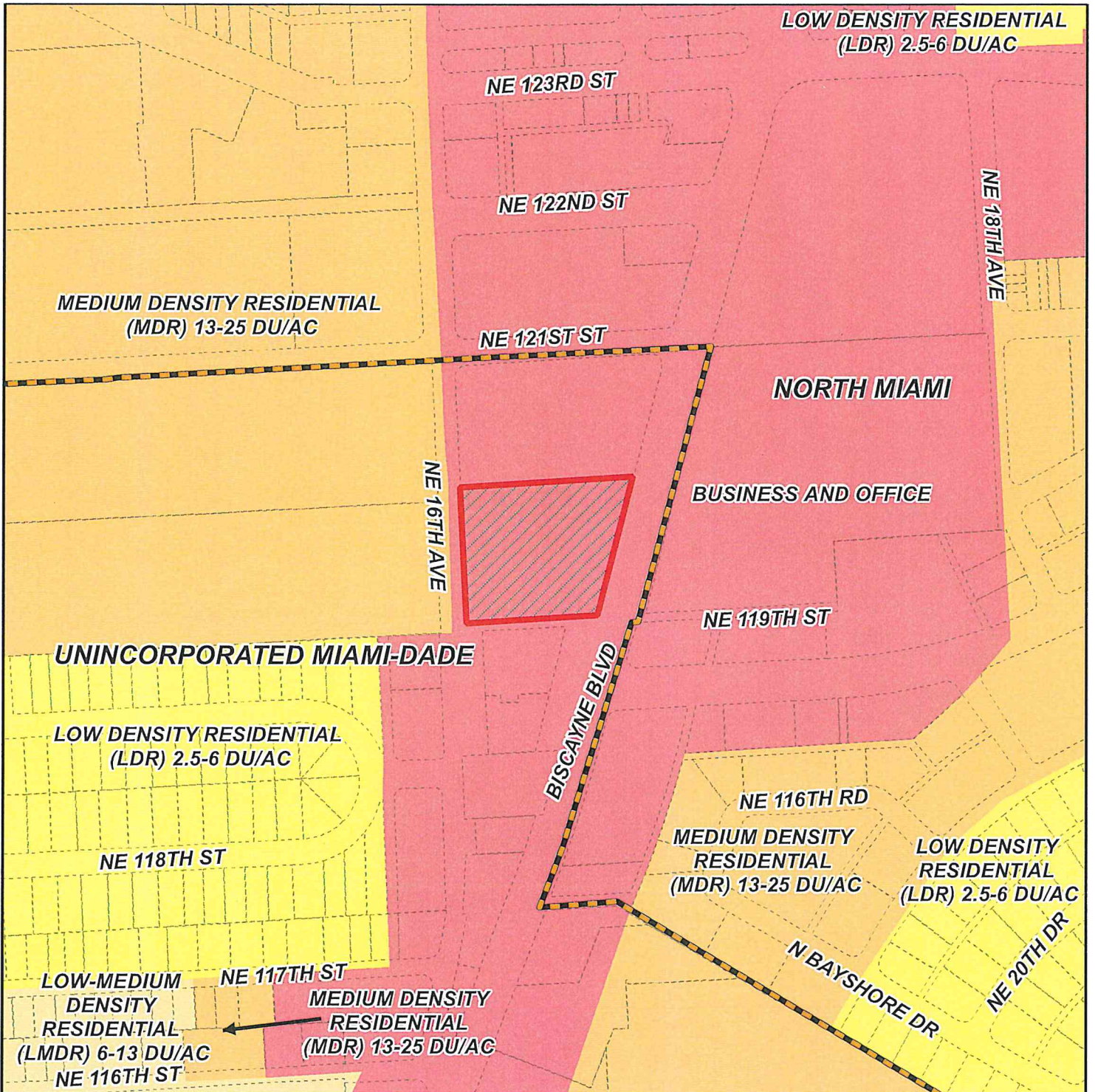

**MIAMI-DADE COUNTY**  
**CDMP MAP**

Process Number  
**Z2024000192**

Section: 29 Township: 52 Range: 42  
 Applicant: Biscayne Real Estate Holdings LLC LLC  
 Zoning Board: C7  
 Commission District: 4  
 Drafter ID: EDUARDO CESPEDES  
 Scale: NTS

**Legend**

 Subject Property Case



SKETCH CREATED ON: Thursday, September 12, 2024

REVISION	DATE	BY

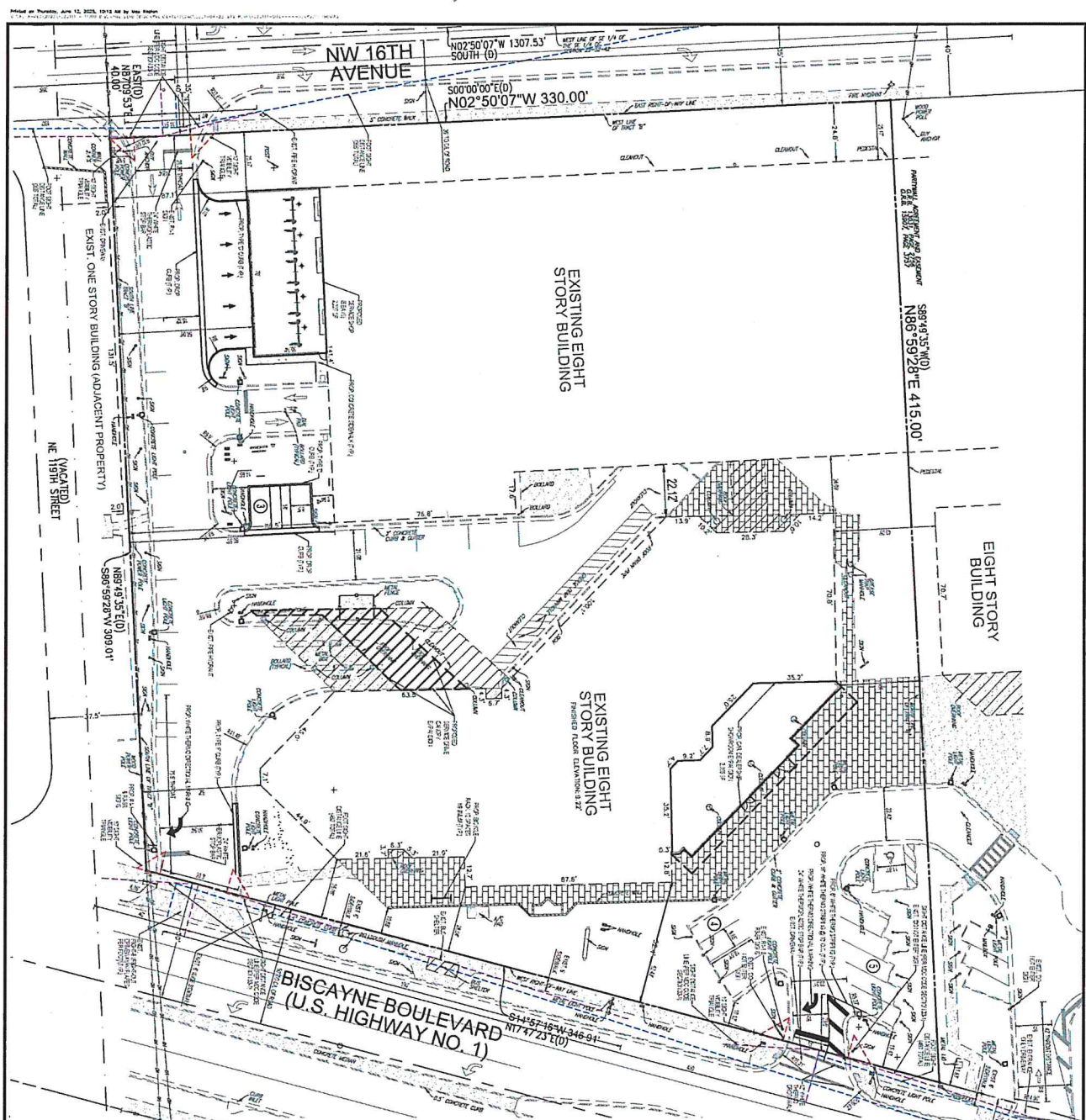

889 93 35 (D) 415.00'

NW 16TH AVENUE  
N02°50'07"W 1307.53'  
SOUTH (D)  
5000.00'E(0)  
N02°50'07"W 330.00'

NE 15TH STREET  
(ADJACENT PROPERTY)

EXISTING EIGHT STORY BUILDING (ADJACENT PROPERTY)

EXISTING EIGHT STORY BUILDING

EIGHT STORY BUILDING

EXISTING EIGHT STORY BUILDING

BISCAYNE BOULEVARD  
(U.S. HIGHWAY NO. 1)

HATCH LEGEND

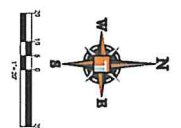

DE-ZONING TABLE

Zoning	MINIMUM BUILDING HEIGHTS	REQUIRED	PROPOSED
Zone 1	40'	40'	40'
Zone 2	40'	40'	40'
Zone 3	40'	40'	40'
Zone 4	40'	40'	40'
Zone 5	40'	40'	40'
Zone 6	40'	40'	40'
Zone 7	40'	40'	40'
Zone 8	40'	40'	40'
Zone 9	40'	40'	40'
Zone 10	40'	40'	40'
Zone 11	40'	40'	40'
Zone 12	40'	40'	40'
Zone 13	40'	40'	40'
Zone 14	40'	40'	40'
Zone 15	40'	40'	40'
Zone 16	40'	40'	40'
Zone 17	40'	40'	40'
Zone 18	40'	40'	40'
Zone 19	40'	40'	40'
Zone 20	40'	40'	40'
Zone 21	40'	40'	40'
Zone 22	40'	40'	40'
Zone 23	40'	40'	40'
Zone 24	40'	40'	40'
Zone 25	40'	40'	40'
Zone 26	40'	40'	40'
Zone 27	40'	40'	40'
Zone 28	40'	40'	40'
Zone 29	40'	40'	40'
Zone 30	40'	40'	40'
Zone 31	40'	40'	40'
Zone 32	40'	40'	40'
Zone 33	40'	40'	40'
Zone 34	40'	40'	40'
Zone 35	40'	40'	40'
Zone 36	40'	40'	40'
Zone 37	40'	40'	40'
Zone 38	40'	40'	40'
Zone 39	40'	40'	40'
Zone 40	40'	40'	40'
Zone 41	40'	40'	40'
Zone 42	40'	40'	40'
Zone 43	40'	40'	40'
Zone 44	40'	40'	40'
Zone 45	40'	40'	40'
Zone 46	40'	40'	40'
Zone 47	40'	40'	40'
Zone 48	40'	40'	40'
Zone 49	40'	40'	40'
Zone 50	40'	40'	40'

**LANDSCAPED OPEN SPACE REQUIREMENTS**

Category	Minimum	Maximum
Open Space	10%	15%
Landscaped Area	5%	10%
Plantings	2%	5%
Water Features	1%	3%
Seating	0.5%	1.5%
Lighting	0.5%	1.5%
Art	0.5%	1.5%
Other	0.5%	1.5%

**PARKING REQUIREMENTS**

Category	Minimum	Maximum
Surface	100	150
Structure	50	75
Other	25	50
Total	175	275

**LEGAL DISCUSSION:**

This document is a site plan for an existing eight-story building. It shows the building's footprint, parking spaces, and surrounding streets. The plan includes various annotations such as 'EXISTING EIGHT STORY BUILDING', 'EXISTING EIGHT STORY BUILDING (ADJACENT PROPERTY)', and 'EXISTING EIGHT STORY BUILDING'. It also shows utility lines, easements, and property boundaries. A north arrow and a scale bar are located in the lower right quadrant of the plan area.

**THOMAS**  
ENGINEERS GROUP  
CIVIL ENGINEERS • PROJECT MANAGERS • LAND PLANNERS • LANDSCAPE ARCHITECTS

100 W. FLETCHER AVE. SUITE 200  
MIAMI, FL 33137  
305.575.1100

100 W. HUNTERS CREEK RD.  
SUITE 100  
JUPITER, FL 33458  
561.746.4444

**Sunshine**  
100 W. HUNTERS CREEK RD.  
SUITE 100  
JUPITER, FL 33458  
561.746.4444

**ASBR**  
100 W. HUNTERS CREEK RD.  
SUITE 100  
JUPITER, FL 33458  
561.746.4444

**THOMAS**  
ENGINEERS GROUP  
100 W. FLETCHER AVE.  
SUITE 200  
MIAMI, FL 33137  
305.575.1100

**Maxwell**  
100 W. HUNTERS CREEK RD.  
SUITE 100  
JUPITER, FL 33458  
561.746.4444

**Kaplan**  
100 W. HUNTERS CREEK RD.  
SUITE 100  
JUPITER, FL 33458  
561.746.4444

**C-1**

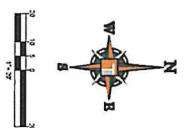
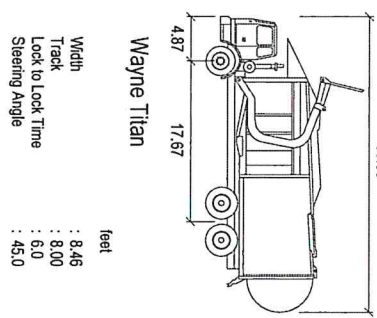
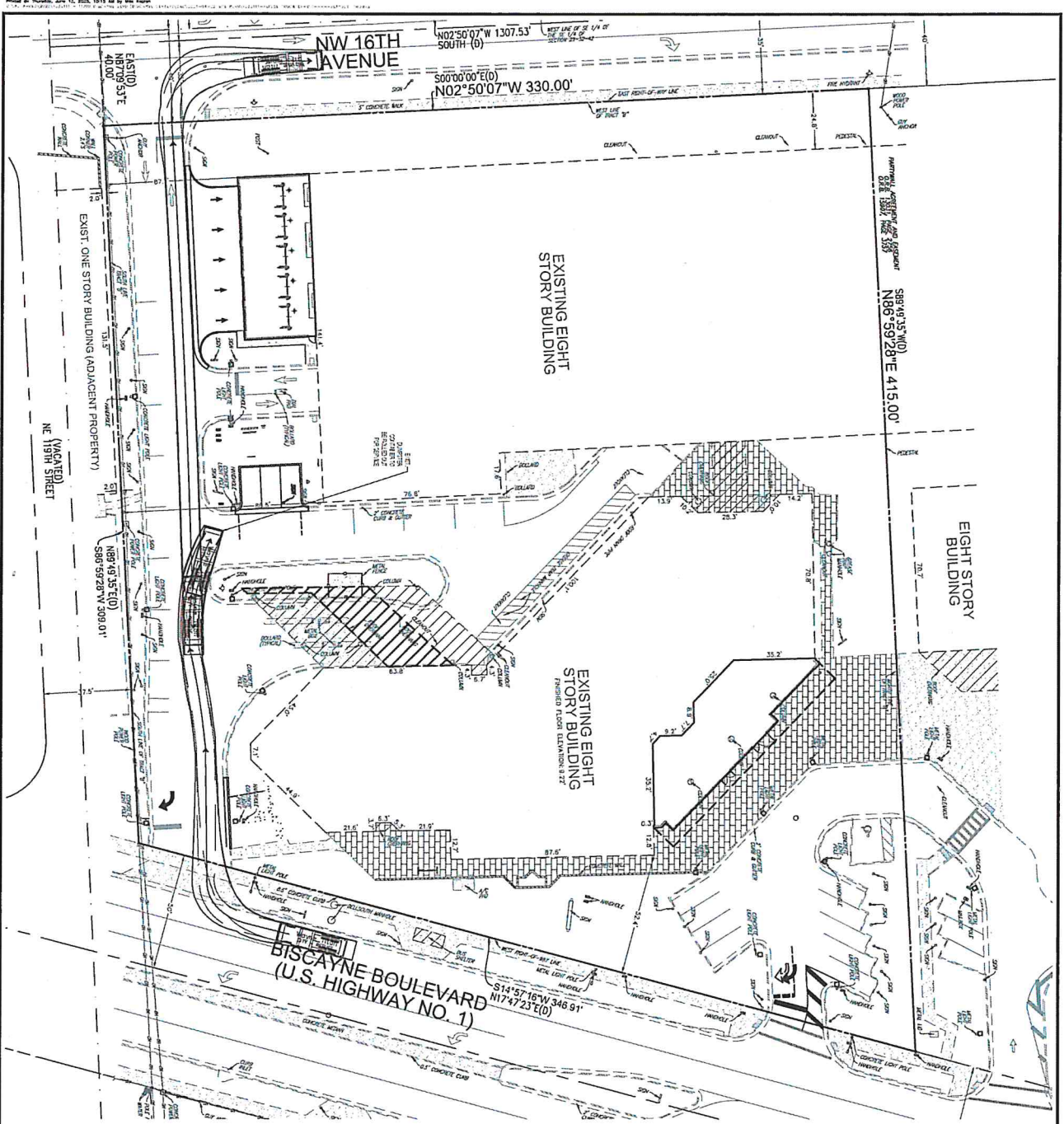

<p>THOMAS ENGINEERS GROUP LEVEL ENGINEERS - PROJECT MANAGERS - LAND PLANNING - LANDSCAPE ARCHITECTS</p> <p>1452 W. BLECHER AVE SUITE 200 TAMPA, FL 33613 P: (813) 253-7500</p> <p>123 W. BAYVIEW BLVD SUITE 200 JUPITER, FL 33408 P: (561) 253-7500</p>	<p><b>Sunshine 811</b></p> <p>Call 811 or visit <a href="http://www.sunshine811.com">www.sunshine811.com</a> to locate underground utilities before you dig. Call 811 or visit <a href="http://www.sunshine811.com">www.sunshine811.com</a> to locate underground utilities before you dig.</p>	<p>ASMR SUBMITTAL</p> <p>PROJECT: BISCAYNE CENTER IMPROVEMENTS 1590 BISCAYNE BLVD.</p> <p>DATE: 10/23/2025</p> <p>ALL DIMENSIONS IN FEET</p>	<p>THOMAS ENGINEERS GROUP</p> <p>1452 W. BLECHER AVE SUITE 200 TAMPA, FL 33613 P: (813) 253-7500</p>	<p>PROJECT TITLE: BISCAYNE CENTER IMPROVEMENTS EXHIBIT</p> <p>PROJECT NUMBER: EX-1</p>
---	---	--	--	--

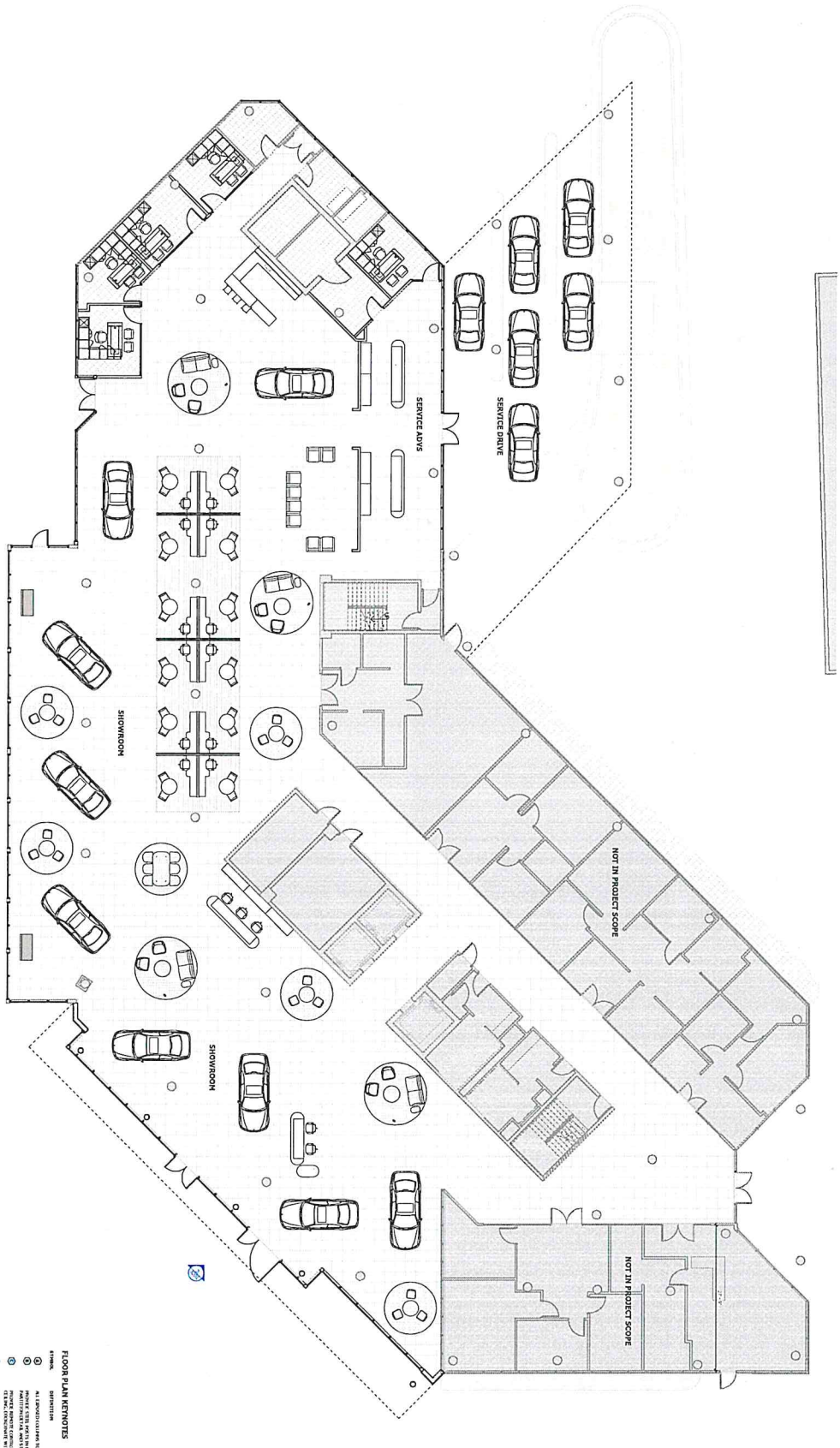

NOT IN PROJECT SCOPE

NOT IN PROJECT SCOPE

NOT IN PROJECT SCOPE

1/4" = 1'-0" Proposed Floor Plan - Showroom

**WALL TYPE LEGEND**

- 1. 1/2" Gypsum Board on Steel Studs
- 2. 5/8" Gypsum Board on Steel Studs
- 3. 1/2" Gypsum Board on Steel Studs
- 4. 5/8" Gypsum Board on Steel Studs
- 5. 1/2" Gypsum Board on Steel Studs
- 6. 5/8" Gypsum Board on Steel Studs
- 7. 1/2" Gypsum Board on Steel Studs
- 8. 5/8" Gypsum Board on Steel Studs
- 9. 1/2" Gypsum Board on Steel Studs
- 10. 5/8" Gypsum Board on Steel Studs

**PROPOSED PLAN LEGEND**

- 1. 1/2" Gypsum Board on Steel Studs
- 2. 5/8" Gypsum Board on Steel Studs
- 3. 1/2" Gypsum Board on Steel Studs
- 4. 5/8" Gypsum Board on Steel Studs
- 5. 1/2" Gypsum Board on Steel Studs
- 6. 5/8" Gypsum Board on Steel Studs
- 7. 1/2" Gypsum Board on Steel Studs
- 8. 5/8" Gypsum Board on Steel Studs
- 9. 1/2" Gypsum Board on Steel Studs
- 10. 5/8" Gypsum Board on Steel Studs

**SCOPE OF WORK LEGEND**

- 1. 1/2" Gypsum Board on Steel Studs
- 2. 5/8" Gypsum Board on Steel Studs
- 3. 1/2" Gypsum Board on Steel Studs
- 4. 5/8" Gypsum Board on Steel Studs
- 5. 1/2" Gypsum Board on Steel Studs
- 6. 5/8" Gypsum Board on Steel Studs
- 7. 1/2" Gypsum Board on Steel Studs
- 8. 5/8" Gypsum Board on Steel Studs
- 9. 1/2" Gypsum Board on Steel Studs
- 10. 5/8" Gypsum Board on Steel Studs

**FLOOR PLAN KEYNOTES**

1. ALL DIMENSIONS ARE TO FACE UNLESS OTHERWISE NOTED.
2. ALL DIMENSIONS ARE TO FACE UNLESS OTHERWISE NOTED.
3. ALL DIMENSIONS ARE TO FACE UNLESS OTHERWISE NOTED.
4. ALL DIMENSIONS ARE TO FACE UNLESS OTHERWISE NOTED.
5. ALL DIMENSIONS ARE TO FACE UNLESS OTHERWISE NOTED.
6. ALL DIMENSIONS ARE TO FACE UNLESS OTHERWISE NOTED.
7. ALL DIMENSIONS ARE TO FACE UNLESS OTHERWISE NOTED.
8. ALL DIMENSIONS ARE TO FACE UNLESS OTHERWISE NOTED.
9. ALL DIMENSIONS ARE TO FACE UNLESS OTHERWISE NOTED.
10. ALL DIMENSIONS ARE TO FACE UNLESS OTHERWISE NOTED.

**Biscayne Automotive**  
11908 Biscayne Boulevard  
Miami, FL 33181

**SPARC**  
Sustainable Procurement and Reporting Center

Project Name: Proposed Floor Plan - Showroom  
Project Number: A101

not released for construction







No.	Botanical Name	Common Name	DDB (Inches)	Height (ft)	Speed (kph)	Condition	Disposition	Category
1	Baccharis lucida	Black Olive	18.5	40	30	Fair	Remove	49
2	Baccharis lucida	Black Olive	21.5	40	30	Fair	Remove	50
3	Baccharis lucida	Black Olive	16	45	30	Fair	Remove	50
4	Pythosporum elegans	Southern Palm	3	12	6	Fair	Remove	25
5	Baccharis lucida	Black Olive	18	40	30	Fair	Remove	25
6	Baccharis lucida	Black Olive	24	45	30	Fair	Remove	45
7	Baccharis lucida	Black Olive	24	45	30	Fair	Remove	45
8	Baccharis lucida	Black Olive	31.5	45	35	Fair	Remove	34
9	Baccharis lucida	Black Olive	25.5	50	35	Fair	Remove	42
10	Baccharis lucida	Black Olive	24	45	35	Fair	Remove	42
11	Baccharis lucida	Black Olive	24.5	40	35	Fair	Remove	47
12	Baccharis lucida	Black Olive	8.5, 4.5, 4.5	22	15	Poor	Remove	132
13	Schinus molle	Urucaria Tree	4.5, 12.5	4	10	Poor	Remove	132
14	Uylandia integrifolia	Shore Pine	14.5, 13, 12.5	30	25	Poor	Remove	180
15	Casahuate	Golden Shower Tree	14.5	30	25	Poor	Remove	180
16	Casahuate	Golden Shower Tree	14.5	30	25	Poor	Remove	180
17	Casahuate	Golden Shower Tree	13	30	25	Poor	Remove	180
18	Casahuate	Golden Shower Tree	22.5, 17.5, 11	30	25	Fair	Remove	41
19	Casahuate	Golden Shower Tree	8.5, 7.0, 6.5	30	30	Fair	Remove	202
20	Casahuate	Golden Shower Tree	10	30	25	Fair	Remove	80
21	Casahuate	Golden Shower Tree	10	30	25	Fair	Remove	314
22	Casahuate	Black Olive	8.5	30	25	Fair	Remove	79
23	Casahuate	Black Olive	0.75, 0.75, 0.7	10	5	Fair	Remove	57
24	Casahuate	Silver Balmwood	5.0, 3.5, 0.75	9	5	Fair	Remove	11
25	Casahuate	Silver Balmwood	0.75, 0.75, 0.7	9	5	Fair	Remove	11
26	Casahuate	Silver Balmwood	1.1, 1.1, 1.1	14	6	Fair	Remove	20
27	Casahuate	Silver Balmwood	1.1, 1.1, 1.1	12	6	Fair	Remove	20
28	Casahuate	Queen Palm	10.5	40	12	Fair	Remove	20
29	Casahuate	Queen Palm	7.5	40	12	Fair	Remove	47
30	Casahuate	Queen Palm	8	30	10	Fair	Remove	50
31	Casahuate	Queen Palm	3.4, 5.5	18	10	Fair	Remove	123
32	Casahuate	Queen Palm	3.8, 3.8, 5.5	16	10	Fair	Remove	113
33	Casahuate	Queen Palm	5.4, 3.5	15	10	Fair	Remove	123
34	Casahuate	Queen Palm	6.4, 3.5	16	10	Fair	Remove	143
35	Casahuate	Queen Palm	3.3, 3.3, 5	10	10	Fair	Remove	221
36	Casahuate	Queen Palm	8	20	12	Fair	Remove	50
37	Casahuate	Queen Palm	8	20	12	Fair	Remove	50
38	Casahuate	Queen Palm	8	20	12	Fair	Remove	50
39	Casahuate	Queen Palm	10.5	50	15	Fair	Remove	47
40	Casahuate	Queen Palm	7	50	12	Fair	Remove	30
41	Casahuate	Queen Palm	3.5	35	12	Fair	Remove	71
42	Casahuate	Queen Palm	9	35	12	Fair	Remove	61
43	Casahuate	Queen Palm	37	50	40	Fair	Remove	107.5
44	Casahuate	Queen Palm	9	45	15	Fair	Remove	64
45	Casahuate	Queen Palm	5	15	10	Fair	Remove	20
46	Casahuate	Queen Palm	9	35	20	Fair	Remove	64
47	Casahuate	Queen Palm	8.5	15	20	Fair	Remove	57
48	Casahuate	Queen Palm	7	12	12	Fair	Remove	30
49	Casahuate	Queen Palm	7	12	12	Fair	Remove	30
50	Casahuate	Queen Palm	9	50	15	Fair	Remove	34
51	Casahuate	Queen Palm	9	50	15	Fair	Remove	64
52	Casahuate	Queen Palm	8	45	15	Fair	Remove	50
53	Casahuate	Queen Palm	9	45	15	Fair	Remove	64
54	Casahuate	Queen Palm	8.5	45	15	Fair	Remove	57
55	Casahuate	Queen Palm	17.5	55	20	Fair	Remove	240
56	Casahuate	Queen Palm	12	12	5	Fair	Remove	30
57	Casahuate	Queen Palm	7	12	12	Fair	Remove	30
58	Casahuate	Queen Palm	7	12	12	Fair	Remove	42
59	Casahuate	Queen Palm	24	30	30	Fair	Remove	42
60	Casahuate	Queen Palm	6	25	18	Fair	Remove	26

NOTE: All invasive trees to be removed including any invasive trees not shown on plan. Canopy sq. ft. removed 131

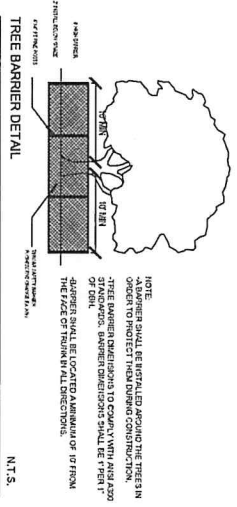

- ONLY REMOVING INVASIVE TREE & TREES 22 & 23.
- 37 TREES REMAINING. 15 PALMS REMAINING.
- EQUALS A TOTAL OF 42 TREES REMAINING AS 3 PALMS=1 TREE.
- CANOPY SQ. FT. BEING REMOVED IS 135 SQ. FT.
- REQUIRES 1 SHADE TREE FOR MITIGATION.



**DIXIE LANDSCAPE**  
 12950 Northwest 112 Ct.  
 Miami, FL 33178  
 P. 305-554-5700 F. 305-554-8543

DATE: 09/24  
 SCALE: 1"=20'  
 DRAWN BY:  
 CHECK BY:  
 SHEET: TD-2  
 OF 2 SHEETS

**BISCAYNE CENTER**  
 Hodgens Construction  
 11900 BISCAYNE BLVD.  
 MIAMI, FL

**TREE DISPOSITION PLAN**

LICENSED PROFESSIONAL  
 Diego Vandebli  
 631  
 Digitally signed by Diego Vandebli  
 DN: cn=Diego Vandebli, o=Diego Vandebli, ou=Diego Vandebli, email=Diego.Vandebli@diegovandebli.com, c=US  
 145591-0100

REG. I VANDERBIL  
 FLORIDA NO. 6867-554  
 (M)

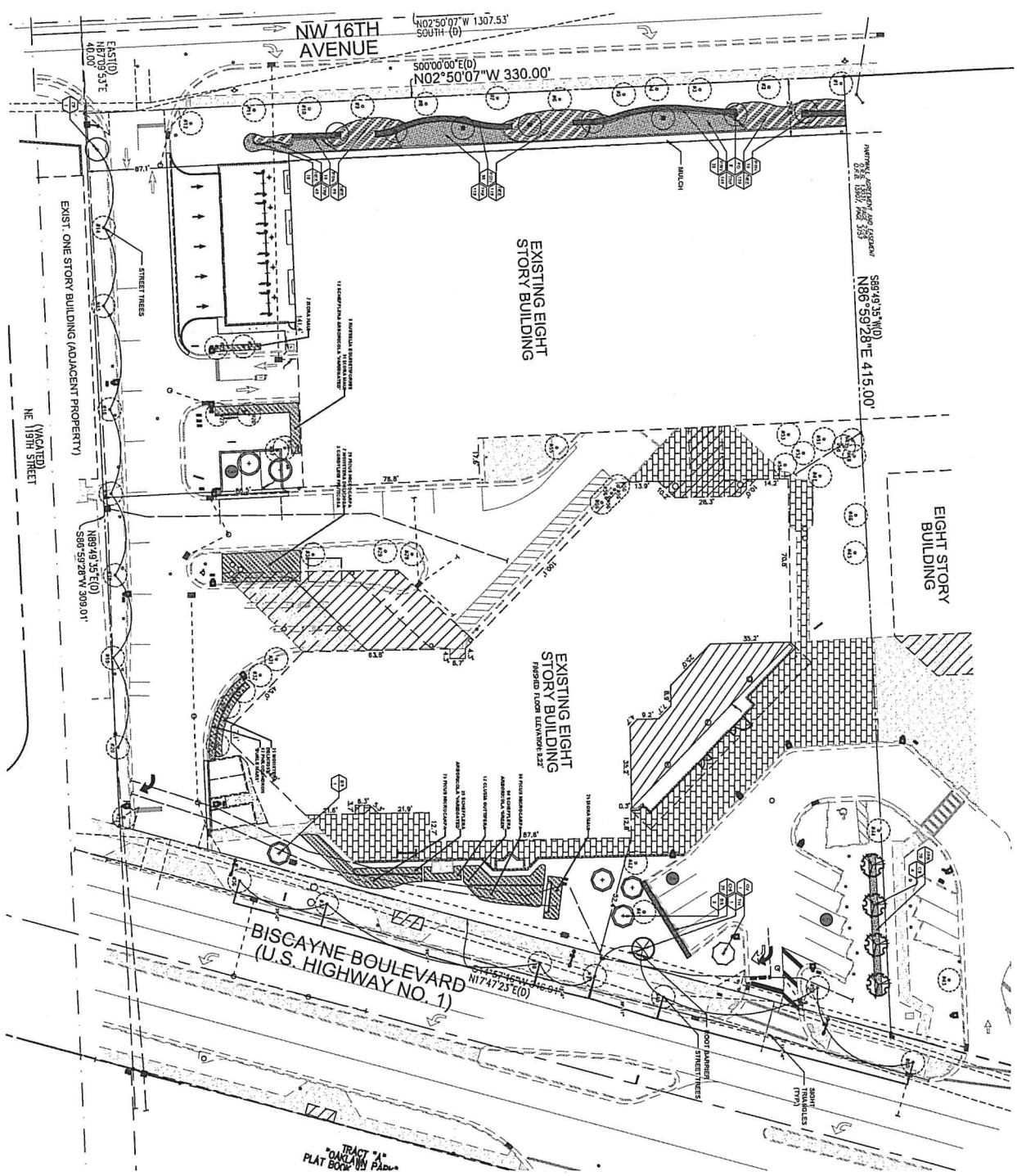

- LEGEND**
- TREE TO REMAIN
  - TREE TO RELOCATE
  - TREE TO REMOVE

**DIXIE LANDSCAPE**  
 12650 Northway 113 Ct.  
 Miami, FL 33158  
 P. 305-554-5700 F. 305-554-8543

DATE: 08.04.24  
 SCALE: 1"=20'-0"  
 DRAWN BY: CHUCK BH  
 CHECK BY: SHAWN  
 SHEET: LA-1  
 OF 2 SHEETS

**BISCAYNE CENTER**  
 Hodgens Construction  
 11900 BISCAYNE BLVD.  
 MIAMI, FL

LANDSCAPE PLAN

LICENSED PROFESSIONAL  
 Diego Vanderbiest  
 Designated by  
 State of Florida  
 DATE: 02.15.2014  
 LICENSE NO: 6697-330

THE CITY OF MIAMI  
 PLANNING DEPARTMENT  
 3200 SW 27th Avenue  
 MIAMI, FL 33135

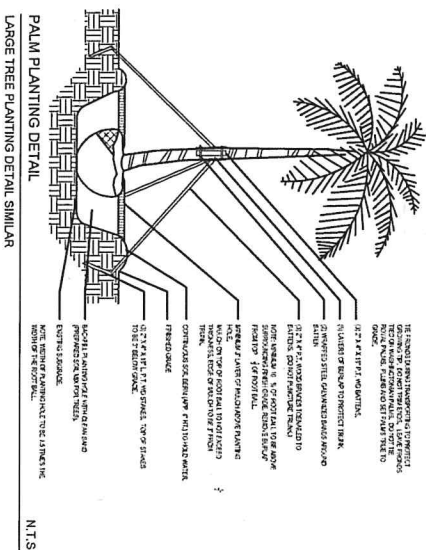

- PLANT NOTES**
1. ALL PLANT MATERIALS TO BE IDENTIFIED, FOR LETTERS IN ROMAN CAPITALS, BY THE LANDSCAPE ARCHITECT OR ANOTHER QUALIFIED PERSON, AND TO BE SUBMITTED TO THE COUNTY ENGINEER FOR APPROVAL PRIOR TO CONSTRUCTION.
  2. ALL PLANTING SHALL BE DONE IN ACCORDANCE WITH THE LATEST EDITION OF THE MICHIGAN LANDSCAPE ARCHITECTURE BOARD'S "STANDARDS AND SPECIFICATIONS FOR LANDSCAPE ARCHITECTURE".
  3. ALL TREES TO BE PLANTED IN ACCORDANCE WITH THE LATEST EDITION OF THE MICHIGAN LANDSCAPE ARCHITECTURE BOARD'S "STANDARDS AND SPECIFICATIONS FOR LANDSCAPE ARCHITECTURE".
  4. LANDSCAPE PLANTING SHALL BE INSTALLED IN COMPLIANCE WITH ALL LOCAL CODES.
  5. ALL SOIL SHALL BE AS BEST AVAILABLE TO THE SOILS DEPARTMENT, UNLESS OTHERWISE SPECIFIED.
  6. ALL PLANTING SHALL BE DONE WITHIN THE PROPOSED CURB OF THE LANDSCAPE AND SHALL BE DONE WITHIN THE PROPOSED CURB OF THE LANDSCAPE AND SHALL BE DONE WITHIN THE PROPOSED CURB OF THE LANDSCAPE AND SHALL BE DONE WITHIN THE PROPOSED CURB OF THE LANDSCAPE.
  7. LANDSCAPE CONTRACTOR SHALL VERIFY ALL DIMENSIONS AND REQUIREMENTS OF ALL PLANTING MATERIALS PRIOR TO ORDERING AND DELIVERY TO THE SITE. LANDSCAPE CONTRACTOR SHALL BE RESPONSIBLE FOR OBTAINING ALL NECESSARY PERMITS AND APPROVALS FROM ALL APPLICABLE AGENCIES AND DEPARTMENTS. LANDSCAPE CONTRACTOR SHALL BE RESPONSIBLE FOR OBTAINING ALL NECESSARY PERMITS AND APPROVALS FROM ALL APPLICABLE AGENCIES AND DEPARTMENTS. LANDSCAPE CONTRACTOR SHALL BE RESPONSIBLE FOR OBTAINING ALL NECESSARY PERMITS AND APPROVALS FROM ALL APPLICABLE AGENCIES AND DEPARTMENTS.
  8. LANDSCAPE CONTRACTOR SHALL VERIFY ALL DIMENSIONS AND REQUIREMENTS OF ALL PLANTING MATERIALS PRIOR TO ORDERING AND DELIVERY TO THE SITE.
  9. TO OBTAIN PERMITS, THE LANDSCAPE CONTRACTOR SHALL BE RESPONSIBLE FOR OBTAINING ALL NECESSARY PERMITS AND APPROVALS FROM ALL APPLICABLE AGENCIES AND DEPARTMENTS.
  10. ALL PLANTING SHALL BE DONE WITHIN THE PROPOSED CURB OF THE LANDSCAPE AND SHALL BE DONE WITHIN THE PROPOSED CURB OF THE LANDSCAPE AND SHALL BE DONE WITHIN THE PROPOSED CURB OF THE LANDSCAPE.

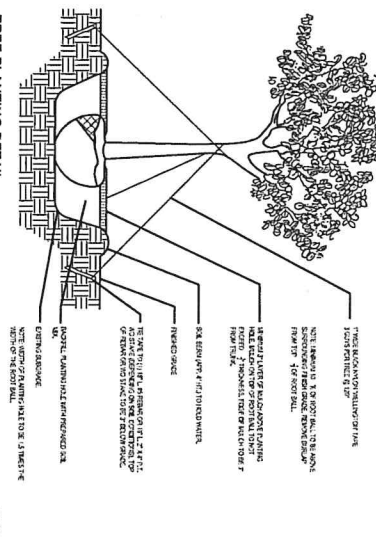

- PLANT NOTES**
1. ALL PLANT MATERIALS TO BE IDENTIFIED, FOR LETTERS IN ROMAN CAPITALS, BY THE LANDSCAPE ARCHITECT OR ANOTHER QUALIFIED PERSON, AND TO BE SUBMITTED TO THE COUNTY ENGINEER FOR APPROVAL PRIOR TO CONSTRUCTION.
  2. ALL PLANTING SHALL BE DONE IN ACCORDANCE WITH THE LATEST EDITION OF THE MICHIGAN LANDSCAPE ARCHITECTURE BOARD'S "STANDARDS AND SPECIFICATIONS FOR LANDSCAPE ARCHITECTURE".
  3. ALL TREES TO BE PLANTED IN ACCORDANCE WITH THE LATEST EDITION OF THE MICHIGAN LANDSCAPE ARCHITECTURE BOARD'S "STANDARDS AND SPECIFICATIONS FOR LANDSCAPE ARCHITECTURE".
  4. LANDSCAPE PLANTING SHALL BE INSTALLED IN COMPLIANCE WITH ALL LOCAL CODES.
  5. ALL SOIL SHALL BE AS BEST AVAILABLE TO THE SOILS DEPARTMENT, UNLESS OTHERWISE SPECIFIED.
  6. ALL PLANTING SHALL BE DONE WITHIN THE PROPOSED CURB OF THE LANDSCAPE AND SHALL BE DONE WITHIN THE PROPOSED CURB OF THE LANDSCAPE AND SHALL BE DONE WITHIN THE PROPOSED CURB OF THE LANDSCAPE.
  7. LANDSCAPE CONTRACTOR SHALL VERIFY ALL DIMENSIONS AND REQUIREMENTS OF ALL PLANTING MATERIALS PRIOR TO ORDERING AND DELIVERY TO THE SITE. LANDSCAPE CONTRACTOR SHALL BE RESPONSIBLE FOR OBTAINING ALL NECESSARY PERMITS AND APPROVALS FROM ALL APPLICABLE AGENCIES AND DEPARTMENTS. LANDSCAPE CONTRACTOR SHALL BE RESPONSIBLE FOR OBTAINING ALL NECESSARY PERMITS AND APPROVALS FROM ALL APPLICABLE AGENCIES AND DEPARTMENTS. LANDSCAPE CONTRACTOR SHALL BE RESPONSIBLE FOR OBTAINING ALL NECESSARY PERMITS AND APPROVALS FROM ALL APPLICABLE AGENCIES AND DEPARTMENTS.
  8. LANDSCAPE CONTRACTOR SHALL VERIFY ALL DIMENSIONS AND REQUIREMENTS OF ALL PLANTING MATERIALS PRIOR TO ORDERING AND DELIVERY TO THE SITE.
  9. TO OBTAIN PERMITS, THE LANDSCAPE CONTRACTOR SHALL BE RESPONSIBLE FOR OBTAINING ALL NECESSARY PERMITS AND APPROVALS FROM ALL APPLICABLE AGENCIES AND DEPARTMENTS.
  10. ALL PLANTING SHALL BE DONE WITHIN THE PROPOSED CURB OF THE LANDSCAPE AND SHALL BE DONE WITHIN THE PROPOSED CURB OF THE LANDSCAPE AND SHALL BE DONE WITHIN THE PROPOSED CURB OF THE LANDSCAPE.

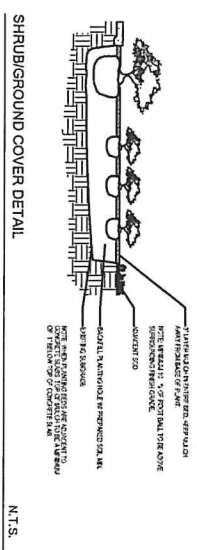

- PLANT NOTES**
1. ALL PLANT MATERIALS TO BE IDENTIFIED, FOR LETTERS IN ROMAN CAPITALS, BY THE LANDSCAPE ARCHITECT OR ANOTHER QUALIFIED PERSON, AND TO BE SUBMITTED TO THE COUNTY ENGINEER FOR APPROVAL PRIOR TO CONSTRUCTION.
  2. ALL PLANTING SHALL BE DONE IN ACCORDANCE WITH THE LATEST EDITION OF THE MICHIGAN LANDSCAPE ARCHITECTURE BOARD'S "STANDARDS AND SPECIFICATIONS FOR LANDSCAPE ARCHITECTURE".
  3. ALL SHRUBS AND GROUND COVERS TO BE PLANTED IN ACCORDANCE WITH THE LATEST EDITION OF THE MICHIGAN LANDSCAPE ARCHITECTURE BOARD'S "STANDARDS AND SPECIFICATIONS FOR LANDSCAPE ARCHITECTURE".
  4. LANDSCAPE PLANTING SHALL BE INSTALLED IN COMPLIANCE WITH ALL LOCAL CODES.
  5. ALL SOIL SHALL BE AS BEST AVAILABLE TO THE SOILS DEPARTMENT, UNLESS OTHERWISE SPECIFIED.
  6. ALL PLANTING SHALL BE DONE WITHIN THE PROPOSED CURB OF THE LANDSCAPE AND SHALL BE DONE WITHIN THE PROPOSED CURB OF THE LANDSCAPE AND SHALL BE DONE WITHIN THE PROPOSED CURB OF THE LANDSCAPE.
  7. LANDSCAPE CONTRACTOR SHALL VERIFY ALL DIMENSIONS AND REQUIREMENTS OF ALL PLANTING MATERIALS PRIOR TO ORDERING AND DELIVERY TO THE SITE. LANDSCAPE CONTRACTOR SHALL BE RESPONSIBLE FOR OBTAINING ALL NECESSARY PERMITS AND APPROVALS FROM ALL APPLICABLE AGENCIES AND DEPARTMENTS. LANDSCAPE CONTRACTOR SHALL BE RESPONSIBLE FOR OBTAINING ALL NECESSARY PERMITS AND APPROVALS FROM ALL APPLICABLE AGENCIES AND DEPARTMENTS. LANDSCAPE CONTRACTOR SHALL BE RESPONSIBLE FOR OBTAINING ALL NECESSARY PERMITS AND APPROVALS FROM ALL APPLICABLE AGENCIES AND DEPARTMENTS.
  8. LANDSCAPE CONTRACTOR SHALL VERIFY ALL DIMENSIONS AND REQUIREMENTS OF ALL PLANTING MATERIALS PRIOR TO ORDERING AND DELIVERY TO THE SITE.
  9. TO OBTAIN PERMITS, THE LANDSCAPE CONTRACTOR SHALL BE RESPONSIBLE FOR OBTAINING ALL NECESSARY PERMITS AND APPROVALS FROM ALL APPLICABLE AGENCIES AND DEPARTMENTS.
  10. ALL PLANTING SHALL BE DONE WITHIN THE PROPOSED CURB OF THE LANDSCAPE AND SHALL BE DONE WITHIN THE PROPOSED CURB OF THE LANDSCAPE AND SHALL BE DONE WITHIN THE PROPOSED CURB OF THE LANDSCAPE.

PLANTLIST				
TREES & PALMS	BOTANICAL NAME	COMMON NAME	DESCRIPTION	
4	BST	Bursera simaruba	12" H, 2" cal	
2	GD7	Coccoloba diversifolia	12" H, 2" cal	
1	GF	Crataegus flava	12" H, 2" cal (Street Tree)	
2	FD	Ficus palmifolia	12" H, 2" cal	
1	GV7	Gleditsia triacanthos	12" H, 2" cal	
1	HH	Hibiscus rosa-sinensis	12" H, 2" cal (Street Tree)	
SHRUBS & GROUNDCOVERS				
QTY	KEY	BOTANICAL NAME	COMMON NAME	DESCRIPTION
20	GF7	Chrysanthemum segetum	Red Top Chrysanthemum	3 gal
20	GF7	Chrysanthemum segetum	Red Top Chrysanthemum	3 gal
20	GF7	Chrysanthemum segetum	Red Top Chrysanthemum	3 gal
300	TH7	Thymus serpyllifolius	Creeping Thyme	3 gal
300	TH7	Thymus serpyllifolius	Creeping Thyme	3 gal

**REQUIREMENTS**

Zoning District: BU-2 Net Lot Area: 2.73 Acres 119,465 s.f.

**OPEN SPACE** Required Provided

Square Feet of open space as required by Chapter 33, as indicated on site plan. Net lot area = 119,465 s.f. x 22% = 26,282 s.f.

**LMN AREA CALCULATION**

A. 39,531 total s.f. of landscaped open space required by Chapter 33

B. Maximum lawn area (good) permitted = 20% x 119,465 s.f. = 23,897

**TREES:**

A. No. trees required per net lot area = 22 BU-2  
Less existing number of trees meeting minimum requirements:  
22 x net lot acres 22 x 2.73 = 60-42

B. % Palms Allowed: No. trees provided x 30% = 8

C. % Natives Required: No. trees provided x 30% = 8

D. Street trees (max. average spacing of 35' o.c.): 677 ft. along street / 35' = 20

E. Street trees located directly beneath power lines (max. spacing of 25' o.c.):  
linear feet along street / 25' = N/A

**SHRUBS:**

A. No. trees required (A + D) x 10 = no. of shrubs required 380

B. No. Shrubs required x 30% = no. of native shrubs required 114 755



**DIXIE LANDSCAPE**

12950 Northwood 113 Ct.  
Miami, FL 33178  
P. 305-594-8700 F. 305-554-8543

DATE: 08/05/24  
SCALE: 1/4" = 1'-0"  
CHECKED BY: [Signature]  
SHEET: LA-2 OF 2 SHEETS

**BISCAYNE CENTER**  
Hodgens Construction  
11900 BISCAYNE BLVD.  
MIAMI, FL

LANDSCAPE DETAILS

UNLICENSED PROFESSIONAL  
Diego Vanderbiest  
Date: 08/05/24  
No. 662735  
FLORIDA LANDSCAPE ARCHITECTURE BOARD

RECEIVED

MIAMI-DADE COUNTY  
PROCESS NO.: Z24-192  
DATE: 05/09/2024  
BY: CABR

**DISCLOSURE OF INTEREST\***

If a **CORPORATION** owns or leases the subject property, list principal stockholders and percent of stock owned by each. [Note: Where principal officers or stockholders consist of other corporation(s), trust(s), partnership(s) or similar entities, further disclosure shall be made to identify the natural persons having the ultimate ownership interest].

CORPORATION NAME: Biscayne Real Estate Holdings, LLC

<u>NAME AND ADDRESS</u>	<u>Percentage of Stock</u>
<u>Ali Ahmed - 5875 N.W. 163 Street - Suite 105, Miami Lakes, FL 33014</u>	<u>20%</u>
<u>Faisal Ahmed - 5875 N.W. 163 Street - Suite 105, Miami Lakes, FL 33014</u>	<u>80%</u>

If a **TRUST or ESTATE** owns or leases the subject property, list the trust beneficiaries and percent of interest held by each. [Note: Where beneficiaries are other than natural persons, further disclosure shall be made to identify the natural persons having the ultimate ownership interest].

TRUST/ESTATE NAME: \_\_\_\_\_

<u>NAME AND ADDRESS</u>	<u>Percentage of Interest</u>
_____	_____
_____	_____
_____	_____
_____	_____
_____	_____

If a **PARTNERSHIP** owns or leases the subject property, list the principals including general and limited partners. [Note: Where partner(s) consist of other partnership(s), corporation(s), trust(s) or similar entities, further disclosure shall be made to identify the natural persons having the ultimate ownership interests].

PARTNERSHIP OR LIMITED PARTNERSHIP NAME: \_\_\_\_\_

<u>NAME AND ADDRESS</u>	<u>Percentage of Ownership</u>
_____	_____
_____	_____
_____	_____
_____	_____
_____	_____

RECEIVED

If there is a **CONTRACT FOR PURCHASE** by a Corporation, Trust or Partnership, list purchasers below including principal officers, stockholders, beneficiaries or partners. [Note: Where principal officers, stockholders, beneficiaries or partners consist of other corporations, trusts, partnerships or similar entities, further disclosure shall be made to identify natural persons having ultimate ownership interests].

CLAY COUNTY  
RECORDER'S OFFICE  
NO. 224-192  
DATE: SEP 9 2024  
BY: CABR

NAME OF PURCHASER: \_\_\_\_\_

NAME, ADDRESS AND OFFICE (if applicable)	Percentage of Interest
_____	_____
_____	_____
_____	_____
_____	_____
_____	_____

Date of contract: \_\_\_\_\_

If any contingency clause or contract terms involve additional parties, list all individuals or officers, if a corporation, partnership or trust:

\_\_\_\_\_  
\_\_\_\_\_  
\_\_\_\_\_

**NOTICE:** For changes of ownership or changes in purchase contracts after the date of the application, but prior to the date of final public hearing, a supplemental disclosure of interest is required.

The above is a full disclosure of all parties of interest in this application to the best of my knowledge and belief.

Signature: \_\_\_\_\_  
(Applicant)

Sworn to and subscribed before me by means of  physical presence or  online notarization this 23<sup>rd</sup> day of August, 2024. Affiant is personally known to me or has produced FDL as identification.

[Signature]  
(Notary Public)

My commission expires 01/24/2028

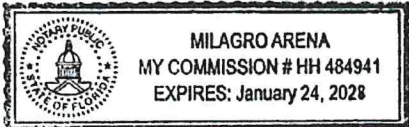

\*Disclosure shall not be required of: 1) any entity, the equity interests in which are regularly traded on an established securities market in the United States or another country; or 2) pension funds or pension trusts of more than five thousand (5,000) ownership interests; or 3) any entity where ownership interests are held in a partnership, corporation or trust consisting of more than five thousand (5,000) separate interests, including all interests at every level of ownership and where no one (1) person or entity holds more than a total of five per cent (5%) of the ownership interest in the partnership, corporation or trust. Entities whose ownership interests are held in a partnership, corporation, or trust consisting of more than five thousand (5,000) separate interests, including all interests at every level of ownership, shall only be required to disclose those ownership interest which exceed five (5) percent of the ownership interest in the partnership, corporation or trust.

# Acknowledgement by Applicant

1. RER Platting and Traffic Review Section, RER Division of Environmental Resources Management (DERM), and other County agencies review and critique zoning hearing applications which may affect the scheduling and outcome of my hearing. These reviews may require additional hearings before DERM's Environmental Quality Control Board (EQCB), or other County boards, and/or the proffering of agreements to be recorded. I am also aware that I must comply promptly with any DERM or Platting and Traffic conditions and advise this office in writing if my application will be withdrawn.
2. Filing fees may not be the total cost of a hearing. Some requests require notices to be mailed to property owners up to a mile from the subject property and I am responsible for paying the additional radius mailing costs. In addition to mailing costs, I am responsible for additional fees related to application changes, plan revisions, deferrals, re-advertising, etc., that may be incurred. I understand that fees must be paid promptly. Applications withdrawn within 60 days of the filing are eligible for a refund of 50% of the hearing fee but after that time hearings withdrawn or returned will be ineligible for a refund. Refunds must be requested in writing.
3. Applicable Florida Building Code requirements may affect my ability to obtain a building permit even if my zoning application is approved; and a building permit will probably be required. I am responsible for obtaining any required permits and inspections for all structures and additions proposed or built without permits. And that a Certificate of Use (C.U.) must be obtained for the use of the property after it has been approved at Zoning Hearing. Failure to obtain the required permits and/or C.U., Certificates of Completion (C.C.) or Certificate of Occupancy (C.O.) will result in enforcement action against any occupant and owner. Submittal of the Zoning Hearing application may not forestall enforcement action against the property.
4. The 3rd District Court of Appeal has ruled that zoning applications inconsistent with the Comprehensive Development Master Plan (CDMP) should not be approved by a zoning board and the recommendation will be for denial or deferral. Therefore, I acknowledge that if the hearing request is inconsistent with the CDMP and I decide to go forward then my hearing request can only be denied or deferred, but not approved. I also understand that I will not be reimbursed any fees paid unless I withdraw within 60 days of filing and then I will receive a 50% refund.
5. Any covenant to be proffered must be submitted to the Department on County forms, at least 1 month prior to the hearing date. The covenant will be reviewed, and the applicant will be notified if changes or corrections are necessary. Once the covenant is acceptable, the applicant is responsible to submit the executed covenant with a current 'Opinion of Title' within 1 week of the hearing. Legal Advisor can advise as to additional requirements applicable to foreign corporations. Documents submitted to the Department must carry a cover letter indicating subject matter, application number and hearing date.

*[Signature]*  
(Applicant's Signature)

Ali Ahmed  
(Print Name of Applicant)

Sworn to and subscribed to before me on the  
23rd day of August, 2024

Affiant is personally known to me or has produced \_\_\_\_\_  
FL DL as identification

*[Signature]*  
Notary Public

Commission expires: 01/24/2028

Print Name: Milagro Arena



# Applicant's Affidavit

RECEIVED

MIAMI-DADE COUNTY  
PROCESS NO.: Z24-192  
DATE: SEP 9 2024  
BY: CABR

Zoning Application No.: \_\_\_\_\_

The Undersigned, first being duly sworn depose that all answers to the questions in this application, and all supplementary documents made a part of the application are honest and true to the best of (my)(our) knowledge and belief. (I)(We) understand this application must be complete and accurate before the application can be submitted and advertised.

Date Stamp Received

## OWNER OR TENANT AFFIDAVIT

(I)(WE), \_\_\_\_\_, being first duly sworn, depose and say that (I am)(we are) the  owner  tenant of the property which is the subject matter of the proposed zoning action.

\_\_\_\_\_  
Signature

\_\_\_\_\_  
Notary Public

Sworn to and subscribed to before me by means of  
 physical presence or  online notarization,

This \_\_\_\_\_ day of \_\_\_\_\_, \_\_\_\_\_

Commission expires: \_\_\_\_\_

## CORPORATION AFFIDAVIT

(I)(WE), Ali Ahmed, being first duly sworn, depose and say that (I am)(we

are) the  President  Vice-President  Secretary  Asst. Secretary  Manager of Biscayne Real Estate Holdings, LLC corporation, and as such, have been authorized by the corporation to file this application for public hearing; and that said corporation is the  owner  tenant of the property which is the subject matter of the proposed zoning action.

Daniella Sanes  
Attest

[Corp. Seal]

\_\_\_\_\_  
Authorized Signature

[Corp. Seal]

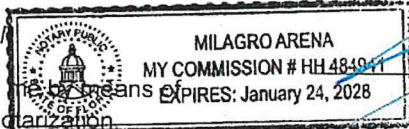

Sworn to and subscribed to before me by means of

physical presence or  online notarization

This 23rd day of August, 2024

Commission expires: 01/24/2028

\_\_\_\_\_  
Notary Public

## PARTNERSHIP AFFIDAVIT

(I)(WE), \_\_\_\_\_, being first duly sworn, depose and say that (I am)(we

are) partners of the \_\_\_\_\_ partnership, and as such, have been authorized to file this application for a public hearing; and that said partnership is the  owner  tenant of the property which is the subject matter of the proposed zoning action.

\_\_\_\_\_  
Name of Partnership

By \_\_\_\_\_ %

By \_\_\_\_\_ %

By \_\_\_\_\_ %

By \_\_\_\_\_ %

Sworn to and subscribed to before me by means of

physical presence or  online notarization,

This \_\_\_\_\_ day of \_\_\_\_\_, \_\_\_\_\_

\_\_\_\_\_  
Notary Public

Commission expires: \_\_\_\_\_



(Space reserved for Clerk)

OWNERSHIP AFFIDAVIT FOR CORPORATION

STATE OF Florida Public Hearing No. \_\_\_\_\_  
COUNTY OF Miami-Dade

Before me, the undersigned authority, personally appeared Ali Ahmed and \_\_\_\_\_ hereinafter the Affiant(s), who being first duly sworn by me, on oath, deposes and says:

1. Affiant is the manager of the Biscayne Real Estate Holdings, LLC, a Florida limited liability company, with the following address: 5875 N.W. 163 Street - Suite 105, Miami Lakes, FL 33014

2. The Corporation owns the property, which is the subject of the proposed hearing.

3. The subject property is legally described as: Please see Exhibit "A"

4. Affiant is legally authorized to file this application for public hearing.

5. Affiant understands this affidavit is subject to the penalties of law for perjury and the possibility of voiding of any zoning granted at public hearing.

Witnesses:

[Signature]  
Signature  
Milagro Arena  
Print Name

[Signature]  
Signature  
Daniella sanes  
Print Name

[Signature]  
Affiant's signature  
Ali Ahmed  
Print Name



RECEIVED

MIAMI-DADE COUNTY

PROCESS NO.: Z24-192

DATE: SEP 9 2024

(Space reserved for Clerk) BY: CABR

Sworn to and subscribed before me on the 23<sup>rd</sup> day of August, 2024.

Affiant is personally known to me or has produced FL DL as identification.

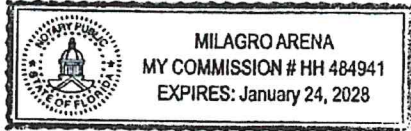

[Signature]  
Notary Public Signature  
Milagro Arena  
Print Name

State of Florida

My Commission Expires: 01/24/2028