

QUALITY. VALUE. ECONOMIC GROWTH.

WWW.MIAMIDADE.GOV/WATER



Sheet Number: 4.5

Product Specifications

Miami-Dade Water & Sewer Department
 Address: 3071 SW 38th Ave, Miami, FL 33146
 Phone: (305) 665-7477

Sewer Check Valve

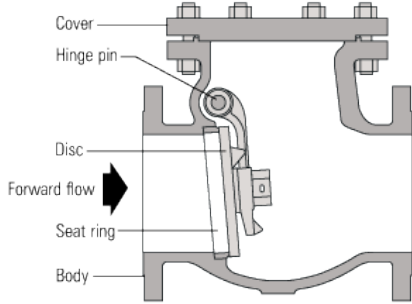

Minimum Standards

- AWWA C508
- ANSI B16.1 Class 125
- ANSI/ASTM A123, A153
- MDWASD Specifications: Sections 40 05 58 (15100), 40 05 65.23 (15115)

Other Requirements

- Iron Body Bronze Mounted
- Clapper Hinge Pin 316 Stainless Steel
- Body and Clapper Seating Surface – Metal to Metal or Resilient to Metal
- Cushioned Check Valves are required for high heads (75ft TDH and above)

Applications

- Sewer

PRE-APPROVED MANUFACTURER

- | | |
|---|-------------------------|
| 1) American Flow Control / American-Darling | 2) Golden Anderson (GA) |
| 3) APCO / DeZURIK | 4) Mueller |
| 5) Clow / M&H / Kennedy | |

Issue Date:

4/4/2016

Revised Date:

6/24/2021

APPROVED PRODUCTS / MODELS

SIZE	MANUFACTURER	MODEL	SUBMITTED
4" - 12"	American Flow Control / American-Darling	Series 600 or 50 line	<input type="checkbox"/>
4" - 24"	APCO / DeZURIK	SERIES 6000, Swing Check Valve	<input type="checkbox"/>
4" - 30"	Clow / M&H / Kennedy	59, 106, 159, 259	<input type="checkbox"/>
4" - 30"	Golden Anderson (GA)	GA Series 340 Swing Check Valves	<input type="checkbox"/>
4" - 30"	Golden Anderson (GA)	GA Series 350 Air Cushioned Check Valves	<input type="checkbox"/>
4" - 30"	Mueller	Series 2600	<input type="checkbox"/>

SIZES FURNISHED:

- | | | | |
|------------------------------|------------------------------|--------------------------------|----|
| <input type="checkbox"/> 4" | <input type="checkbox"/> 12" | <input type="checkbox"/> 20" | |
| <input type="checkbox"/> 6" | <input type="checkbox"/> 14" | <input type="checkbox"/> 24" | 24 |
| <input type="checkbox"/> 8" | <input type="checkbox"/> 16" | <input type="checkbox"/> 30" | |
| <input type="checkbox"/> 10" | <input type="checkbox"/> 18" | <input type="checkbox"/> Other | |

COMMENTS:

APPROVED PRODUCTS / MODELS

SIZE	MANUFACTURER	MODEL	SUBMITTED
------	--------------	-------	-----------

Approved by: MDWASD Departmental Standards, Specifications, and Product Committee

Revision History

3-7-2019: Updated Model Numbers for GA Check Valves; Updated Requirements to allow resilient to metal;

6-24-2021: Updated American Flow Control to American Flow Control / American-Darling and APCO to APCO / DeZURIK